

Contents

- Required Tools and Equipment 2
- Environmental Requirements 2
- Taking ESD Precautions 2
- Unpacking the Library..... 3
- Accessory Kit Contents 6
- Installing the Library in a Rack or Desktop Kit..... 6
- Installing the Tape Drives 6
- Connecting the Cables..... 8
- Turning the Library ON and Configuring Network Settings 9
- Changing the Home Screen on the Operator Panel 13
- Accessing the Library Via the Web Client 14
- Configuring Partitions..... 15
- Running the Installation and Verification Test 15
- Importing Tape Cartridges 16
- Saving the Library Configuration 18
- Configuring the Host Software..... 18
- Registering the Library..... 19

Scalar i40 and Scalar i80 Quick Start Guide

This quick start guide provides basic installation and configuration instructions for the Scalar® i40 and Scalar i80 libraries. For more information, see the *Quantum Scalar i40 and Scalar i80 User's Guide* located on the documentation CD provided with your library.

This instruction uses the following conventions:

Caution: Cautions indicate potential hazards to equipment and are included to prevent damage to equipment.

WARNING: Warnings indicate potential hazards to personal safety and are included to prevent injury.



Scalar i80



Scalar i40

Required Tools and Equipment

- Ethernet cable

Environmental Requirements

The installation site must have the following environmental conditions:

- Humidity 20% – 80% non-condensing
- Temperature: 50°F – 95°F (10°C – 35°C)
- Altitude: –500 to 10,000 feet (–152 to 3048 meters)

These environmental conditions apply when the Scalar i40 and Scalar i80 libraries are in operation. For additional specifications, refer to the *Quantum Scalar i40 and Scalar i80 User's Guide*.

In addition, install the library in a location that is as free from dust as possible. Dust can damage or degrade performance of library components and media.

Taking ESD Precautions

Some components within the Scalar i40 and Scalar i80 libraries contain static-sensitive parts. To avoid damaging these parts while performing installation procedures, always observe the following precautions:

- Use an antistatic wrist strap. If you do not have one, touch the outside of the library on the sheet metal before touching any components to discharge static from your body.
- Keep static-sensitive parts in their original shipping containers until ready for installation. Look for the ESD sticker to identify static sensitive parts.



- Avoid touching connectors and other components.

Note: Dry climates and cold-weather heating environments have lower relative humidity and are more likely to produce static electricity.

Unpacking the Library

Note: Unpack the library as close to the installation location as possible.

- 1 Inspect the outer library packaging for damage. If there is any damage evident on the library packaging, do not continue with the installation and contact Quantum customer support.
- 2 Open the library packing box and remove the kit tray containing the accessory kit and rail kit (see [Figure 1](#)). Some configurations come with tape drives installed in the library, and some come with tape drives packaged separately. If yours comes with tape drives packaged separately, remove them and set aside for installation later.

Figure 1 Packaging

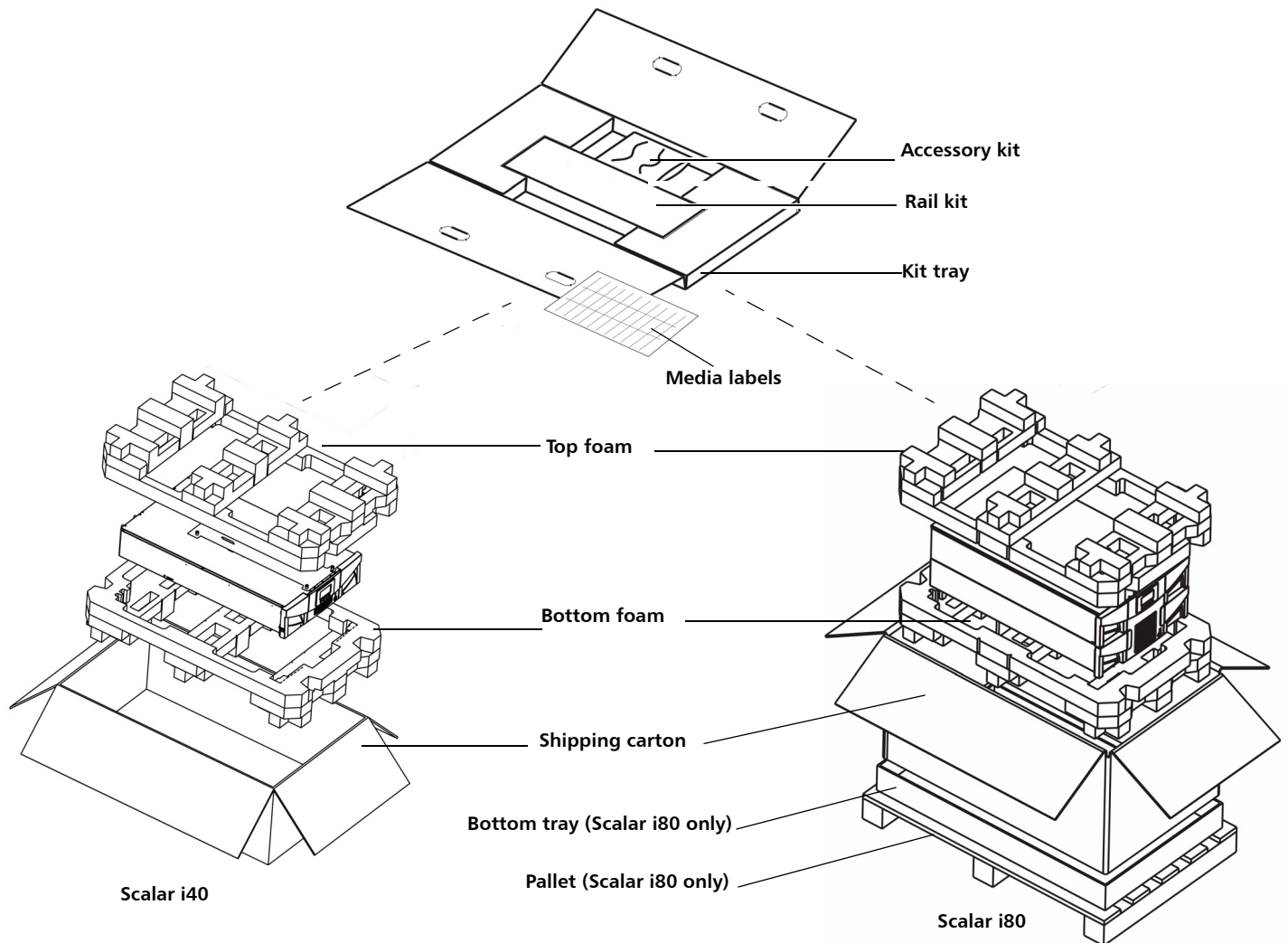



- 3 Remove the top foam.
- 4 **Scalar i80 only:** Remove the shipping carton by lifting it straight up out of the bottom tray.
- 5 With the help of a second person, lift the library chassis out of the bottom foam and place it on a table approximately waist high.

WARNING: Two people are required to safely lift the library out of its packaging or into a rack.

Caution: Lift the library chassis at the sides. Avoid putting the weight of the library chassis on the front bezel.

- 6 Remove the anti-static wrapping from the library. Keep the anti-static wrapping intact so that you can use it later if needed.
- 7 Save the packing box, packaging material, and anti-static wrapping in case you need to move or ship the library in the future.
- 8 Remove the Y-tray restraint. The robot restraint consists of four (4) thumbscrews, a plastic sheet, a small metal clip, and underneath the plastic sheet, an orange restraint tab (see [Figure 2](#))— located on the top cover of the library.
 - a Unscrew and remove the four thumbscrews from the top cover. Save the thumbscrews in case you need to move or ship the library in the future.
 - b Remove the plastic sheet and metal clip and discard. You will not need to use them again.

Figure 2 Removing the Robot Restraints

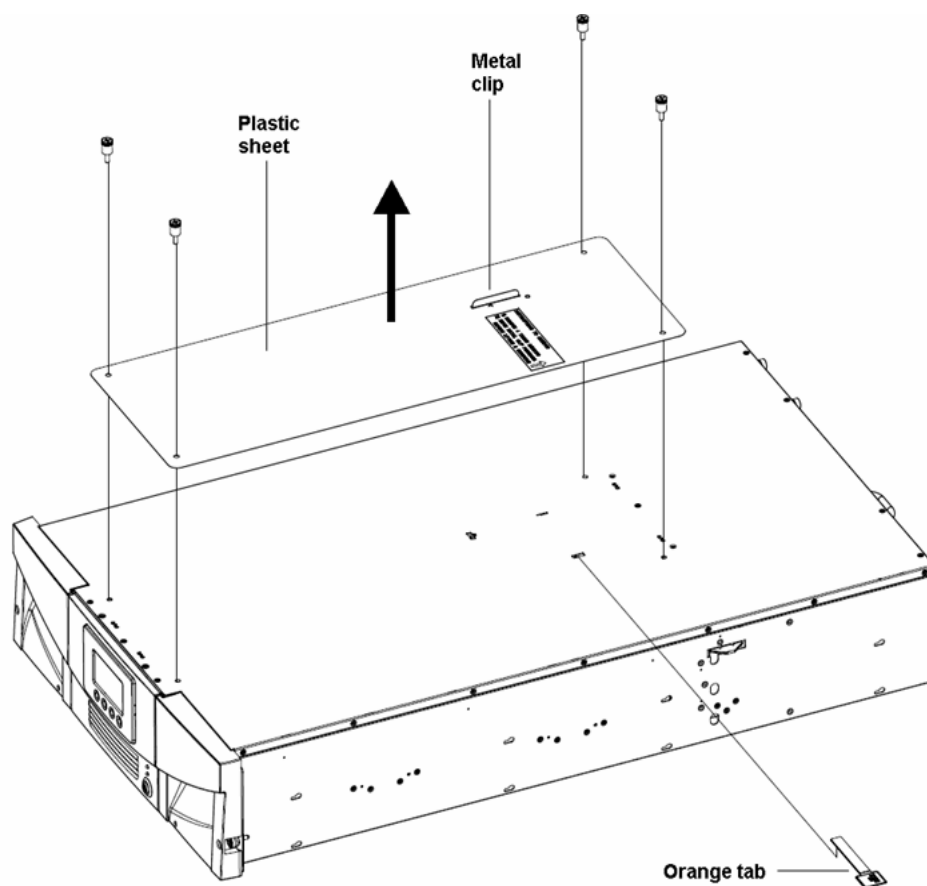

- c Remove the orange shipping restraint tab and discard. You will not need to use it again.

Note: The robot may stay at the top of the library, or it may move downward toward the floor of the library. If it moves downward, you will hear the gears turning as it moves. This is normal.

- 9 Once you remove the Y-tray restraints, you may cover the holes in the library top cover with stickers, which are provided in the accessory kit for this purpose. This step is optional and is intended to prevent small objects from accidentally falling into the library through the holes.
- 10 Remove the protective plastic sheet covering the front panel display.

Accessory Kit Contents

- Power cord(s) – one for each power supply
- *Scalar i40 and Scalar i80 Documentation and Training CD*
- *Scalar i40 and Scalar i80 Quick Start Guide*
- *China RoHS* statement
- *System, Safety, and Regulatory Information Guide*
- Stickers (clear, round) to cover holes in library top cover

Installing the Library in a Rack or Desktop Kit

Follow the instructions that came with your rail kit or desktop kit to install the library.

Installing the Tape Drives

If your library already has tape drives installed, skip this section.

Tape Drive Slot Location Considerations

Tape drives can only fit in certain slots, as described below and illustrated in [Figure 3](#). Slots are numbered starting from the bottom and moving up.

- **Scalar i40:** Half-height tape drives can be installed in slots 1 and 2.
- **Scalar i80:** Half-height tape drives can be installed in slots 1, 2, 3, 4, and 5.

It is recommended to start installing the tape drives at the bottom slot and work up, without leaving spaces between.

Figure 3 Acceptable Installation Locations for Half-Height Tape Drives

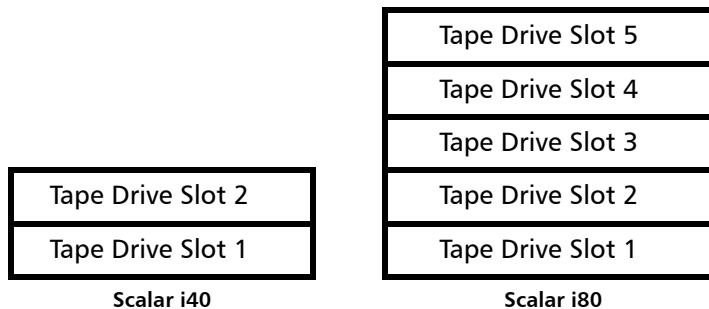

Installation Instructions

- 1 If needed, remove filler plates from the back of the library to make room for the tape drives. Unscrew the two captive thumbscrews and pull the filler plates out of the library. Save the filler plates in case you need to use them in the future.
- 2 Unpack the tape drive and tape drive cable.

Caution: The tape drive always resides in a drive sled, and together they are effectively one unit. Do not remove the tape drive from the drive sled.

- 3 Insert the tape drive into the drive slot. The “shelf” on the bottom of the drive sled fits into the notch in the library chassis and slides on the plastic guide rails (see [Figure 4](#)). The tape drive must be level to slide in smoothly. At the very end of the slide, you will feel a slight “click” as the tape drive sled connector connects into its mating connector in the library chassis.

Figure 4 Installing a Tape Drive

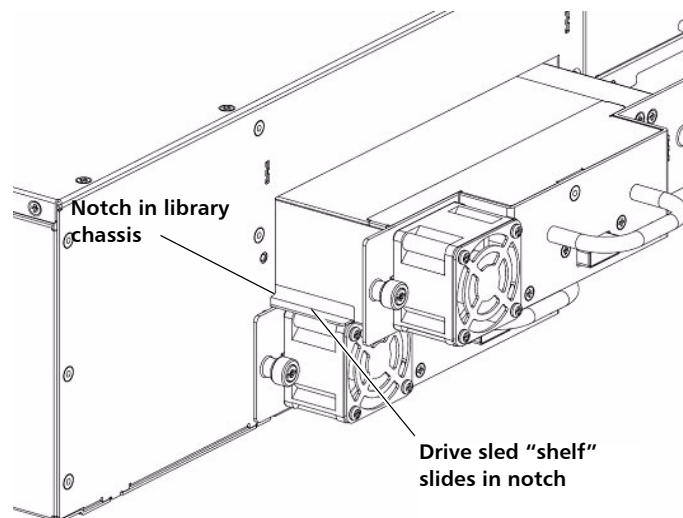

- 4 Tighten the tape drive’s captive thumbscrews finger tight to secure the tape drive to the library chassis.
- 5 Install a filler plate over any open tape drive slot. If you need more filler plates, contact Quantum.

Caution: Filler plates are required to maintain proper library cooling. Do not run the library with uncovered slots.

Connecting the Cables

Connect the cords and cables as follows (see [Figure 5](#)). It is recommended that you leave some slack in the cables to allow you to perform replacement procedures in the future.

- 1 Connect the tape drive cables from the tape drives to the host.

Note: Cables for full-height Fibre Channel tape drives must be installed in the LEFT port as you view the installed tape drive from the rear of the library.

Caution: Use care when handling the fibre optic cables. Do not crimp or bend the cables. Do not exceed the bend radius specified by the manufacturer.

- 2 Connect an Ethernet cable (not supplied) into the LEFT port on the system control board (SCB). The right SCB port is for service use only; do not use. Connect the other end of the Ethernet cable into a live Ethernet jack connected to your network.
- 3 Connect the power supply cord into the power supply connector. Plug the other end of the cord into a grounded AC outlet.

Figure 5 Connection Locations

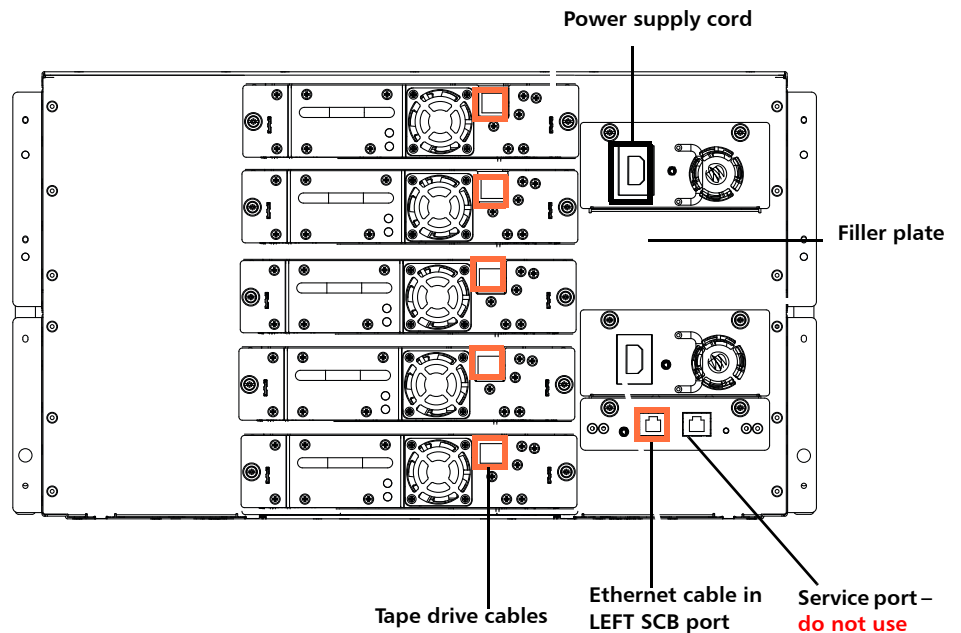

Turning the Library ON and Configuring Network Settings

Caution: Before turning the library on, make sure you removed the shipping restraint (4 thumbscrews, mylar sheet, metal clip, and orange tab) from the top of the library! Otherwise, the library will not initialize. See [Figure 2](#) on page 5.

- 1 Turn the library **ON** by pressing the power button on the front bezel (see [Figure 6](#)).
 - The green power LED on the front panel above the power button illuminates, and the LCD screen turns on. The library goes through a connection and initialization sequence. This can take 5 to 17 minutes, depending on the size of your library.
 - The status LED on the rear of each drive sled turns green during initialization.

Figure 6 Turning on the Library

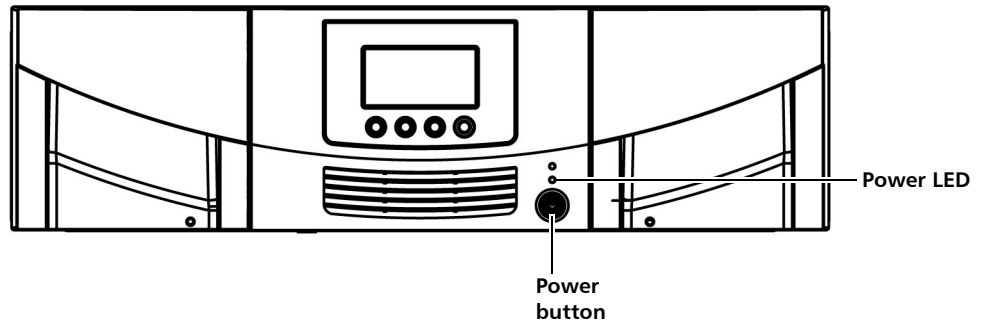

When initialization completes, the **Setup Wizard** screen appears on the operator panel (see [Figure 7](#)). The operator panel screen contains a menu bar with operations that correspond to the four physical buttons below it. The menu operations and button functions change with each screen.

Figure 7 Setup Wizard – Initial Screen

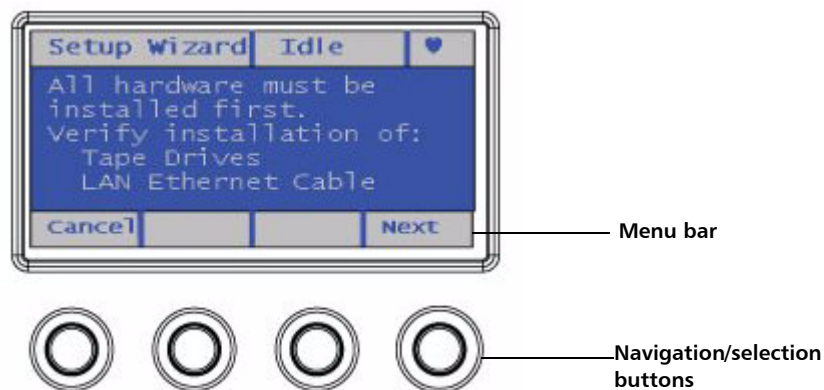

- 2 Before proceeding, verify the Ethernet cable is connected and all of your tape drives are installed.

3 Do one of the following:

- To configure basic network settings using the Setup Wizard, press the button corresponding to **Next** on the menu bar. You will be guided through a series of screens where you can accept or change the default configuration settings (date, time, IP address, licenses, partitions, I/E station slots, and cleaning slots). Once you accept a setting, you move to the next one. Remember that you can always change the configuration later if needed.
- To cancel out of the Setup Wizard and begin using the library immediately, press the button corresponding to **Cancel** on the menu bar. This accepts the library's default configuration, including an IPv4 address assigned by DHCP. The Setup Wizard will not appear on the operator panel again, but you can change any of the configuration settings later using the **Setup** menus on the operator panel or the Web client. It is easier to configure the library using the Web client, so you may wish to cancel now. To access the Web client immediately, skip the rest of this section and go to [Accessing the Library Via the Web Client](#) on page 14.

The **Setup Date/Time** screen appears (see [Figure 8](#)).

Figure 8 Setup Wizard – Date/Time Screen



4 Do one of the following:

- To accept the date and time, press the **Accept** button.
- To change the date or time, press the **Change** button. The **Date** field becomes available to edit and the menu bar button designations change. Use the **Left** and **Right** buttons to move through the date field, one segment at a time. Use the **Up** and **Down** buttons to change each segment of the date value. You can press the **Up** or **Down** button repeatedly to change the value, or you can hold the button in for fast scrolling. As you press **Right**, each segment of the date fills in. Continue to press the **Right** button to go to the **Time** field and edit it the same way. See [Figure 9](#). When you reach the last segment of the **Time** field, the **Right** button designation changes to **Apply**. Press the **Apply** button. The new date and time display, and you can **Accept** or **Change**. Once you press **Accept**, you move to the next step.

Figure 9 Changing the Date and Time

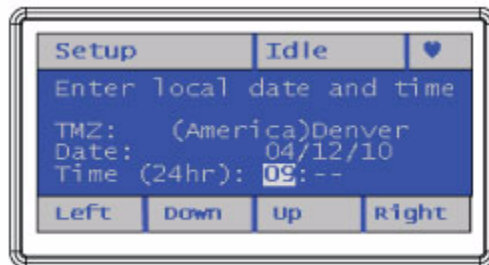

Note: You cannot change the time zone on the operator panel. You can change it later using the Web client.

The **Setup Network** screen appears, listing a default host name (which you cannot change here but you can change later on the Web client) and an IPv4 address assigned by DHCP (see [Figure 10](#)).

Figure 10 Setup Wizard – Setup Network Screen

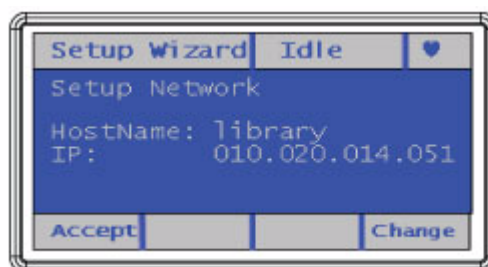

5 Do one of the following:

- To accept the IP address, press the **Accept** button.
- To change the IP address, press the **Change** button. Complete the network configuration screens and press **Accept** when finished.
 - If you accept IPv4 as the protocol, you can choose to get an IP address via DHCP or enter a static IP address. If you choose DHCP, the IP address, mask, and gateway are displayed. If you choose not to use DHCP, use the directional buttons as described in [Step 3](#) on page 10 to enter a static IP address, mask, and gateway.
 - If you choose IPv6 as the protocol, the library supplies a stateless IPv6 address and displays it, along with other network settings, on two screens. Use the **Next** and **Back** buttons to view the screens. You can only change these settings via the Web client.

The **Current Licenses** screen appears, which lists the number of licensed and unlicensed slots in the library and the licenses currently installed (see [Figure 11](#)).

You may have received, separately, License Key Certificates containing instructions on how to retrieve your desired license key from the Quantum Web site.

- 6 Once you have retrieved your license key, you may add it now or any time later. (If you did not receive your License Key Certificate, contact the place of purchase.)

Figure 11 Setup Wizard – Licenses Screen

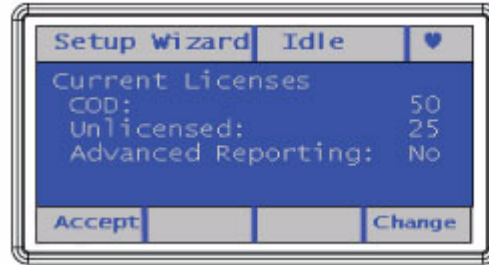

- 7 Do one of the following:
 - To accept the settings and go to the next step, press **Accept**.
 - To change the settings, press **Change**. You can only change the settings if you have a new license key to enter. If you have a license key, press **Add**, then enter the license key using the directional buttons as described in [Step 3](#) on page 10 and press **Accept** when complete. If you need to add another license key, perform the Change operation again.

The **Current Configuration** screen appears, displaying the default number of partitions, I/E station slots, and cleaning slots (see [Figure 12](#)).

Figure 12 Setup Wizard – Current Configuration Screen



- 8 Do one of the following:
 - To accept the current settings, press **Accept**.
 - To change any of the settings, press **Change**. This will delete the current partitions, and you are asked to confirm you want to do this. If you agree, the library deletes the partitions, which takes about 30 seconds. When the partitions are deleted, you are guided through several more screens to change the number of partitions, I/E station slots, and cleaning slots. Use the directional buttons as described in [Step 3](#) on page 10 and press **Accept** when complete.

- **Partitions** — The minimum number of partitions you can create using the operator panel is equal to the number of distinct combinations of tape drive interface type (Fibre Channel or SAS), media generation (LTO-4, LTO-5), and slot availability—of the currently installed tape drives. The maximum number of partitions you can create is equal to the number of tape drives installed in the library. The library assigns resources proportionately among the partitions. You can change resource allocation and configure partitions with more flexibility later via the Web client. For details, see the *Scalar i40 and Scalar i80 User's Guide*.
- **I/E Station Slots** — On the Scalar i40, you can configure 0, 5, or 20 I/E station slots. On the Scalar i80, you can configure 0, 5, 10, 20, 25, or 40 I/E station slots. The minimum is zero. Be aware that if you configure zero I/E station slots, you will not be able to import and export tape cartridges.
- **Cleaning Slots** — You can configure a minimum of zero and a maximum of four cleaning slots. For more information about cleaning slots, see the *Scalar i40 and Scalar i80 User's Guide*.

The Setup Wizard is complete (see [Figure 13](#)).

Figure 13 Setup Wizard Complete



- 9 Press the **Exit** button.

Changing the Home Screen on the Operator Panel

From the operator panel, you may choose to change the default home screen to an alternate home screen that facilitates easy I/E unlock access, displays the number of I/E slots and the number of I/E slots that are full.

Changes to the home screen can be made only from the operator panel.

- 1 Select **Setup > System Settings** and press **Select**.
- 2 Select **Alternate Home** and press **Modify**.
- 3 Select **Up** to choose **Unlock I/E**, and press **Apply**.
- 4 Select **Exit** twice to return to the alternate home screen.

Accessing the Library Via the Web Client

It is recommended that you use the Web client to perform most library functions. The Web client is easier to use than the operator panel, and it presents more information and options than the operator panel does. Refer to the *Scalar i40 and Scalar i80 User's Guide* or Web client online help for detailed instructions on how to use the Web client.

To access the library via the Web client:

- 1 From the operator panel, press the **Reports** button.
- 2 Press the **Down** button until **Network Settings** is highlighted.
- 3 Press the **Select** button.
- 4 Make note of your library's IP address that is displayed on the screen.
- 5 Enter the IP address in your Internet browser to bring up the library's Web client login screen.
- 6 Enter the default user name: **admin**
- 7 Enter the default password: **password**
- 8 Click **OK**.

Installing the Latest Firmware

Download the latest library firmware using one of the following methods:

- If the library has an internet connection, use the Web client to update the library to the latest firmware.
 - 1 Click **Tools > Update Library Firmware**.
 - 2 Read the EULA agreement.
 - 3 Click **Update library firmware with the version from the Quantum Support Web site** check box.
 - 4 Click **Apply**.
- If the library does not have an internet connection, do the following:
 - 1 Using a Web browser connected to the internet go to <http://www.quantum.com/ServiceandSupport/SoftwareandDocumentationDownloads/SI40/Index.aspx> and click the **Firmware** tab.
 - 2 Download the library firmware to a known location on your computer.
 - 3 Using the Web client, go to **Tools > Update Library Firmware**
 - 4 Click **Browse** to select the firmware image you downloaded.
 - 5 Click **Apply**.

You can also view your library's current firmware version by selecting **Reports > About Library** from the operator panel, or **Reports > About > Scalar i40/i80** from the Web client.

Configuring Partitions

At least one partition is necessary for proper setup. You may wish to configure partitions via the Web client if the Setup Wizard could not set them up exactly as you want them. To configure partitions via the Web client, select **Setup > Partitions**. Follow the instructions in the online help or the *Scalar i40 and Scalar i80 User's Guide*.

Note: If you bypassed the Setup Wizard partition setup, a single partition with all drives and all slots will be set up, adhering to the connection type and generation of the installed drive(s). Use the Web client to modify setup as desired.

Running the Installation and Verification Test

The Installation and Verification Test (IVT) is used to evaluate a newly installed library. It calibrates the robot to the library, verifies that the Y-tray is functioning properly, and verifies that the magazines and tape drives are installed correctly and reachable by the robot. The test also verifies that barcode labels can be read by the robot scanning operation. See the *Scalar i40 and Scalar i80 User's Guide* for more details.

To run the IVT:

- 1 Unlock the I/E station.

From the operator panel

- a Press the **Actions** button, then press the **Down** button to select **I/E**, then press **Select**.
- b Select **Unlock I/E Station** and press the **Select** button.

If the library contains more than one I/E station, select the top right I/E station and press **Unlock**. The robot moves to the I/E station and unlocks it.

Note: If you are viewing the alternate home screen, select **Unlock**.

From the Web client

- a Select **Operations > I/E Station Unlock**.
 - b Select an I/E station to unlock and click **Apply**.
 - c Click **Apply** to confirm and click **OK**.
- 2 When the operator panel display prompts you, pull out on the magazine door until it stops. If you wait more than 30 seconds, the I/E station re-locks.

- 3 Insert a scratch tape cartridge in the top I/E station slot. Make sure the cartridge is properly labeled and right-side-up.

Note: All tape cartridges must have a unique, external barcode label that is machine readable. Quantum-supplied barcode labels provide the best results (labels are packaged along with your library). Barcode labels supplied by other sources can be used, but they must meet specific requirements (for details, see the “Barcode Requirements” section of the *Scalar i40 and Scalar i80 User's Guide*).

- 4 Close the magazine by pushing it in until it stops.

The robot moves to the I/E station and scans the newly installed tape cartridge. When finished, the operator panel asks you to assign the cartridges to a partition.

- 5 Assign the cartridge to the **System** partition. Use the **Up** and **Down** buttons to select **System**, then press the **Apply** button.

- 6 Select **Tools > IVT**.

- 7 Press **Yes** to start the test.

The test progress and pass/fail status display on the operator panel screen. Refer to the *Scalar i40 and Scalar i80 User's Guide* if any of the tests fail.

Importing Tape Cartridges

The following instructions describe how to import tape cartridges via the operator panel. You may also import tape cartridges via the Web client (see the online help or the *Scalar i40 and Scalar i80 User's Guide*). The Web client allows you to import multiple tape cartridges while the operator panel only allows you to import one at a time.

You need to use the I/E station to import tape cartridges.

Note: If you configured zero I/E station slots, you cannot import tape cartridges and will need to bulk load tape cartridges instead. See the *Scalar i40 and Scalar i80 User's Guide* for instructions.

Locations of the I/E stations:

- **Scalar i40** — The I/E station is located in the first column of the right magazine.
- **Scalar i80** — Based on the setting selected, the following slots are configured:

Setting Selected	Slots Configured
5	Right top front 5
10	Right top front 5 Right bottom front 5
20	Right top 20
25	Right top 20 Right bottom front 5
40	Right top 20 Right bottom 20

To import tape cartridges:

- 1 Unlock the I/E station.
 - a From the operator panel, press the **Actions** button, then press the **Down** button to select I/E, then press **Select**.
 - b Select **Unlock I/E Station** and press the **Select** button.
 - c If the library contains more than one I/E station, select an I/E station and press **Unlock**.

The robot moves to the I/E station and unlocks it.

- 2 When the operator panel display prompts you, pull out on the magazine door until it stops. If you wait more than 30 seconds, the I/E station re-locks.
- 3 Insert tape cartridges into the I/E station slots. Make sure the cartridges are properly labeled and right-side-up.

Note: All tape cartridges must have a unique, external barcode label that is machine readable. Quantum-supplied barcode labels provide the best results (labels are packaged along with your library). Barcode labels supplied by other sources can be used, but they must meet specific requirements (for details, see the “Barcode Requirements” section of the *Scalar i40 and Scalar i80 User's Guide*).

- 4 Close the magazine by pushing it in until it stops.

The robot move to the I/E station and scans the newly installed tape cartridges. When finished, the operator panel asks you to assign the cartridges to a partition.

- 5 Assign the cartridges to a partition. Use the **Up** and **Down** buttons to select a partition, then press the **Apply** button.

Note: You must assign all the newly installed tape cartridges to the same partition. If you want to assign them to different partitions, you need to disable manual cartridge assignment and use the Web client. See the *Scalar i40 and Scalar i80 User's Guide* for details.

- 6 Import the tape cartridges.
 - a Press the **Down** button to select I/E and press the **Select** button.
 - b Press the **Down** button to select **Import Tape** and press the **Select** button.
 - c Use the **Up** and **Down** buttons to select a single tape cartridge or **ALL** tape cartridges and press the **Import** button. (The **ALL** option is only available if there are enough empty slots in the selected partition to accommodate all the cartridges.)

The robot imports the tape cartridge(s) into the partition you selected.
 - d When the operator displays an "import complete" message, press the **OK** button.
 - e Repeat steps a through c for any remaining tape cartridges in the I/E station.
- 7 Repeat the above steps until all your tape cartridges are imported.

Saving the Library Configuration

Save the library configuration every time you change the configuration or firmware. From the Web client, select **Tools > Save/Restore Configuration > Save System Configuration**. Click **Apply**. Save the file to a known location.

Configuring the Host Software

Before you can use the library for backup, you need to configure your host application. Refer to your host software documentation for instructions on configuring your host. Refer to the *Scalar i40 and Scalar i80 User's Guide* for instructions on how to obtain information from the library, such as host name, WWPN, and so on.

Registering the Library

Registering the library activates the warranty. After completing the initial setup of the library, choose **Setup > Register Library** from the Web client to access the online product registration form.



For assistance, contact the Quantum Customer Support Center:

USA: 800-284-5101 (toll free) or 949-725-2100
EMEA: 00800-4-782-6886 (toll free) or +49 6131 3241 1164
APAC: +800 7826 8887 (toll free) or +603 7953 3010
Worldwide: <http://www.quantum.com/ServiceandSupport>

Quantum[®]

Preserving the World's Most Important Data. Yours.™

©2011 Quantum Corporation. All rights reserved. Quantum, the Quantum logo, and all other logos are registered trademarks of Quantum Corporation or of their respective owners. Protected by Pending and Issued U.S. and Foreign Patents, including U.S. Patent No. 5,990,810.

About Quantum

Quantum Corp. (NYSE:QTM) is the leading global storage company specializing in backup, recovery and archive. Combining focused expertise, customer-driven innovation, and platform independence, Quantum provides a comprehensive range of disk, tape, media and software solutions supported by a world-class sales and service organization. This includes the DXi™-Series, the first disk backup solutions to extend the power of data deduplication and replication across the distributed enterprise. As a long-standing and trusted partner, the company works closely with a broad network of resellers, OEMs and other suppliers to meet customers' evolving data protection needs.