

Scalar i500 Getting Started Guide

Das *Scalar i500 - Einführungshandbuch* ist auf Deutsch auf der CD *Scalar i500 Documentation and Training* erhältlich, welche sich im Zubehörsatz befindet.

Le *Guide de démarrage rapide de la bibliothèque Scalar i500* est disponible en français sur le CD *Scalar i500 Documentation and Training* qui se trouve dans le kit d'accessoires.

La *Guía de inicio de Scalar i500* está disponible en español en el CD *Scalar i500 Documentation and Training* que se localiza dentro del kit de accesorios.

Руководство по началу работы со Scalar i500 на русском языке находится на прилагаемом компакт-диске *Scalar i500 Documentation and Training*.

日本語の『*Scalar i500 スタートガイド*』は付属品キットの『*Scalar i500 Documentation and Training CD*』で利用可能です。

한국어판 *Scalar i500 시작 안내서*가 액세서리 키트에 있는 *Scalar i500 Documentation and Training CD*에 있습니다.

*Scalar i500 快速入门指南*简体中文版可在套件包里的 *Scalar i500 Documentation and Training CD* 中找到。

Introduction	3
Step 1: Unpack the Library	4
Step 2: Install the Rackmount Kit (Optional for 5U and 14U)	5
Step 3: Install the Module(s)	5
Using the Control Module as a Standalone Unit	5
Using a Multi-Module Library Configuration	5
Step 4: Install the Module Components	10



Step 5: Connect the Tape Drive Cables	11
Connecting Parallel SCSI Cables	11
Connecting Fibre Channel Cables Directly to Host or Switch	13
Connecting Fibre Channel Cables Through an I/O Blade	14
Connecting Serial Attached SCSI (SAS) Cables	15
Step 6: Connect the Library Cables	16
Step 7: Configure the Library Settings	17
Step 8: Run the Library	19

Made in the USA.

Quantum Corporation provides this publication "as is" without warranty of any kind, either express or implied, including but not limited to the implied warranties of merchantability or fitness for a particular purpose. Quantum Corporation may revise this publication from time to time without notice.

COPYRIGHT STATEMENT

© Copyright 2008 by Quantum Corporation. All rights reserved.

Your right to copy this manual is limited by copyright law. Making copies or adaptations without prior written authorization of Quantum Corporation is prohibited by law and constitutes a punishable violation of the law.

TRADEMARK STATEMENT

Quantum, the Quantum logo, and Scalar are registered trademarks of Quantum Corporation.

Other trademarks may be mentioned herein which belong to other companies.

Introduction

The *Scalar i500 Getting Started Guide* provides an overview of the steps required to unpack, set up, and install the Scalar i500 library. For more detailed information on configuring and running your library as well as adding, removing, and replacing parts, see the *Scalar i500 User's Guide*.

Release Notes are also available for this product. The Release Notes describe changes to your system or firmware since the last release, provide compatibility information, and discuss any known issues. The Release Notes can be found at www.quantum.com. You can find a list of additional documentation in the *Scalar i500 User's Guide*.

Note: Before operating this product, read all instructions and warnings in this document and in the *System, Safety, and Regulatory Information Guide*. In addition, be sure to use this document in conjunction with the *Scalar i500 User's Guide*.

Warning: Without tape drives, tape cartridges, or power supplies, a 5U control module weighs approximately 58 lbs. A 9U expansion module, without tape drives, tape cartridges, or power supplies, exceeds 65 lbs. To avoid serious injury, two people are required to safely lift the modules into position.

Warning: The power outlet must be available near the library and must be easily accessible.

Warning: All libraries taller than 14U must be installed in a rack having a main protective earthing (grounding) terminal, and power must be supplied via an industrial plug and socket-outlet and/or an appliance coupler complying with IEC 60309 (or an equivalent national standard) and having a protective earth (ground) conductor with a cross sectional area of at least 1.5 mm² (14 AWG).

To ensure proper airflow and access space, Allow 60 cm (24 inches) in the front and back of the library.

Warning: Under no circumstances should a rack be moved while loaded with one or more modules.

Step 1: Unpack the Library

1 Unpack the library.

Following the unpacking instructions that came with the library, remove the library exterior packaging but leave the library in the bottom packaging tray.

Caution: Save all packing materials in case you need to move or ship the library in the future.

2 Check the contents of the package against the packing slip.

3 Remove the interior packaging.

Caution: Be sure to remove the following items:

- The strap holding the robot in place. Release the velcro and unhook each end of the strap.
- All cardboard and foam surrounding the robot.

Warning: Without tape drives, tape cartridges, or power supplies, a 5U control module weighs approximately 58 lbs. A 9U expansion module, without tape drives, tape cartridges, or power supplies, exceeds 65 lbs. To avoid serious injury, two people are required to safely lift the modules into position.

4 Remove the tape drives from the library.

For information about removing tape drives, see the *Scalar i500 User's Guide*.

5 Remove the power supplies from the library.

For information about removing power supplies, see the *Scalar i500 User's Guide*.

6 Choose an optimal location for the library.

To avoid damage, the library must be positioned in a stable location. See the *System, Safety, and Regulatory Information Guide* for more information on finding an optimal location for your library.

Warning: The power outlet must be available near the library and must be easily accessible.

- Make sure a power source (only of the type marked on the product label) is available. For power requirements, see the *Scalar i500 User's Guide*.
- Route any cables to avoid walking on them or pinching them with items placed on or against them. Pay particular attention to the cord at the wall receptacle and the point where the cord exits from the library. For recommended cabling procedures, see the *Scalar i500 User's Guide*.
- Make sure that objects will not fall and liquids will not spill into the library's chassis through openings.

Step 2: Install the Rackmount Kit (Optional for 5U and 14U)

All Scalar i500 libraries taller than 14U must be installed in a rack. The rack secures the bottom module, and all other modules are then secured to the bottom module. Installing the modules into the rack requires at least two people. For instructions, see “Installing the Rackmount Kit” in the *Scalar i500 User’s Guide*.

Step 3: Install the Module(s)

There are two possible library configurations:

- [Using the Control Module as a Standalone Unit](#)
- [Using a Multi-Module Library Configuration](#)

Using the Control Module as a Standalone Unit

- 1 Open the library’s I/E station door and access door.

Note: If the I/E station door is locked, refer to the *Scalar i500 User’s Guide* for unlocking instructions.

- 2 Lift the control module and place it in the desired location.
- 3 If you are placing the control module in a rack, use the rack ears to fasten the control module to the rack. For instructions, see “Installing the Rackmount Kit” in the *Scalar i500 User’s Guide*.
- 4 Continue installation with [Step 4: Install the Module Components](#) on page 10.

Using a Multi-Module Library Configuration

Follow these instructions if you are installing a new multi-module library, or if you are adding expansion modules to an existing library.

Required tools:

- Phillips #2 screwdriver, for removing and replacing the top cover plate
- T10 TORX screwdriver, for removing and replacing the bottom cover plate

There are no restrictions on where the control module can be installed in the library configuration. However, the recommended placement of the control module for library configurations up to 32U is on top of all installed 9U expansion modules. The

recommended placement of the control module for 41U library configurations is on top of three 9U expansion modules and below the top expansion module.

				Cover Plate
			Cover Plate	Expansion Module
		Cover Plate	CONTROL MODULE	CONTROL MODULE
	Cover Plate	CONTROL MODULE	Expansion Module	Expansion Module
Cover Plate	CONTROL MODULE	Expansion Module	Expansion Module	Expansion Module
CONTROL MODULE	Expansion Module	Expansion Module	Expansion Module	Expansion Module
Cover Plate	Cover Plate	Cover Plate	Cover Plate	Cover Plate
5U	14U	23U	32U	41U

- 1 Park the robot assembly in the control module.
 - a Open the I/E station and access doors of each module.
 - b Using your hands, gently lift the robot assembly into the control module. The robot assembly should glide slowly and with some resistance.

Caution: Support the robot assembly by holding onto the broad metal X-axis plate. Lifting the robot by the thin metal rod will bend the rod.

- c After raising the robot assembly to the approximate middle of the control module, hold it in place with one hand and, using your other hand, swivel the parking tab toward you. The metal parking tab is located at the bottom of column 1.
 - d Gently release the robot assembly to rest on the parking tab.

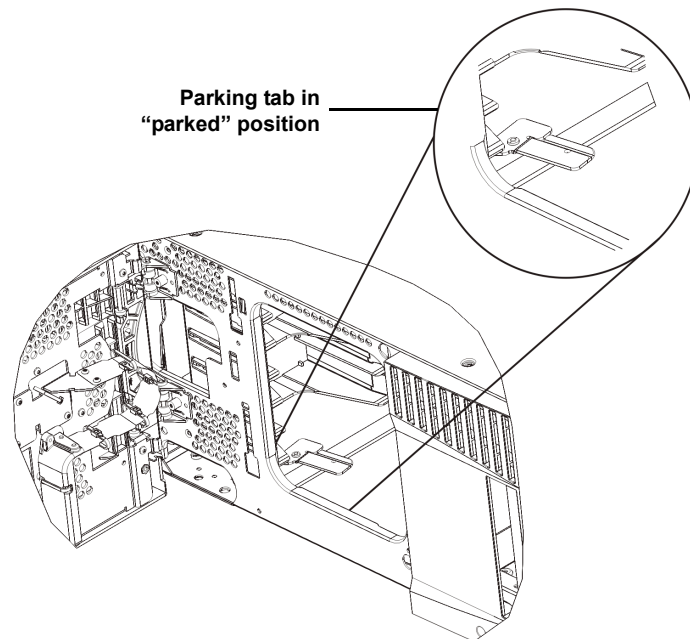

2 Remove top or bottom cover plates if necessary.

There should only be one top cover and one bottom cover plate in the final configuration. There should be no cover plates in between modules.

3 Install the expansion module(s).

- a** Open the 9U expansion module's access door and raise the guide pin by pulling it up and turning it slightly as if it were a screw. Otherwise, the guide pin may scratch the front doors of the module on which you are stacking.

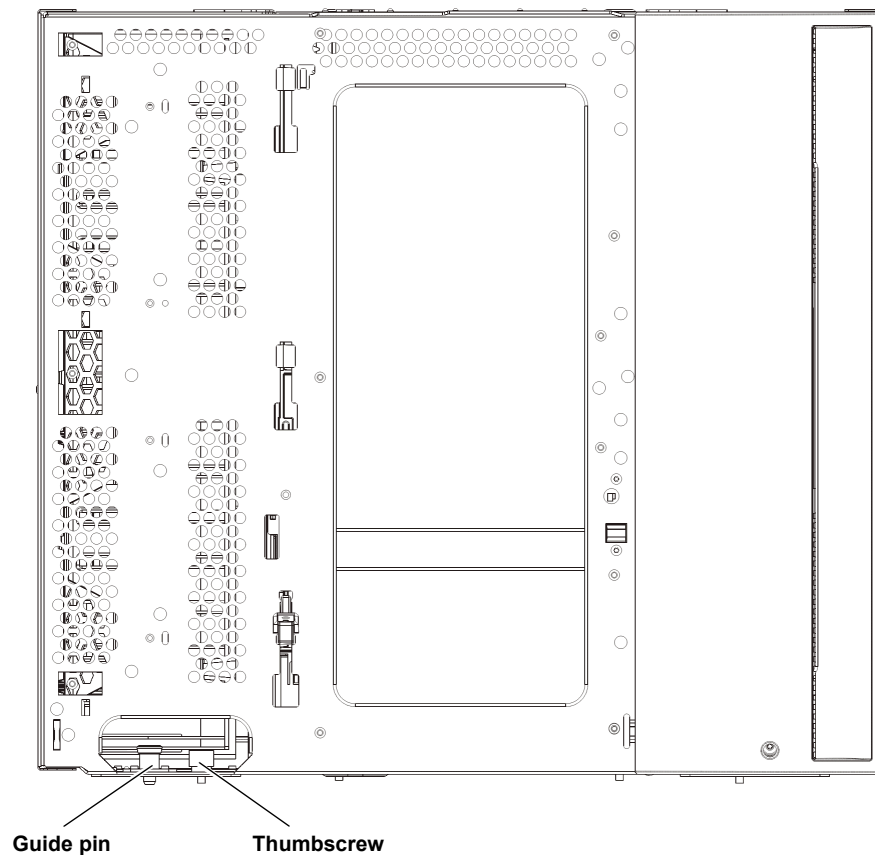

- b** Lift the new expansion module and, from the front of the library, place it in the desired location.
- c** If stacking the expansion module on top of another module, lower the module's guide pin (located at the base of the front of the module) by turning it and pushing it down. Then secure the two modules together by tightening the two thumbscrews at the base of the front of the module and the two thumbscrews located at the base of the back of the module.
- d** Tighten all thumbscrews located at the base of the front and back of the modules.
- e** Fasten the module to the rack with rack ears. For instructions, see "Installing the Rackmount Kit" in the *Scalar i500 User's Guide*.
- f** If stacking the expansion module on top of another module, engage the Y-rails of the new module in your library configuration. Ensure that the Y-rails are properly aligned and the thumbscrews are tightened.

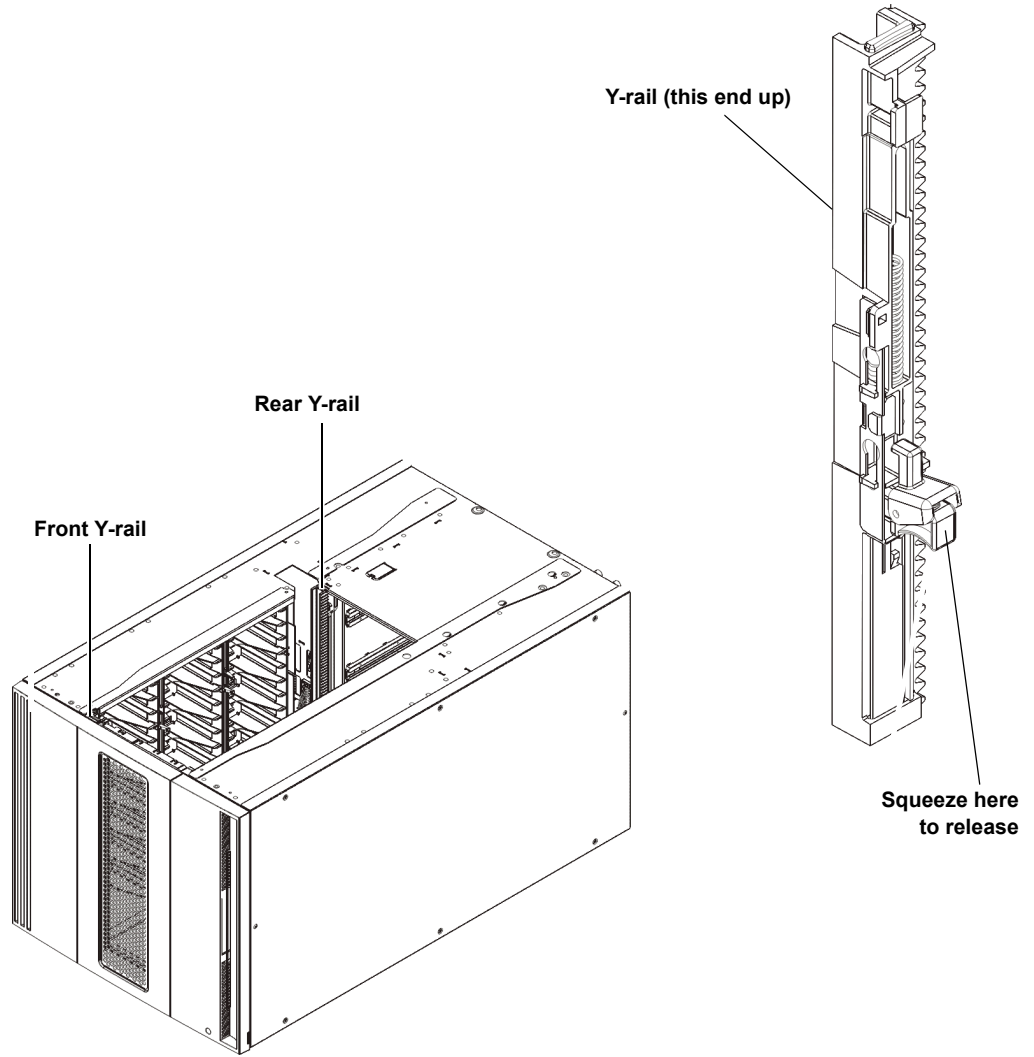

- g** From the front of the library, open the I/E station and access doors of the expansion module. Squeeze the handle of the Y-rail release mechanism, lift it out of its locked position, and slide it downward as far as it will go.
- h** From the back of the library, find the rear Y-rail release mechanism, which is located in the interior of the right side of the module. Squeeze the handle of the Y-rail release mechanism, lift it out of its locked position, and slide it downward as far as it will go.

Caution: Check to make sure that there is no gap between the top and bottom Y-rails on both the front and back of the library. If a gap exists, the library cannot mechanically initialize.

Doing this aligns the Y-rails with the Y-rails of the module beneath it.

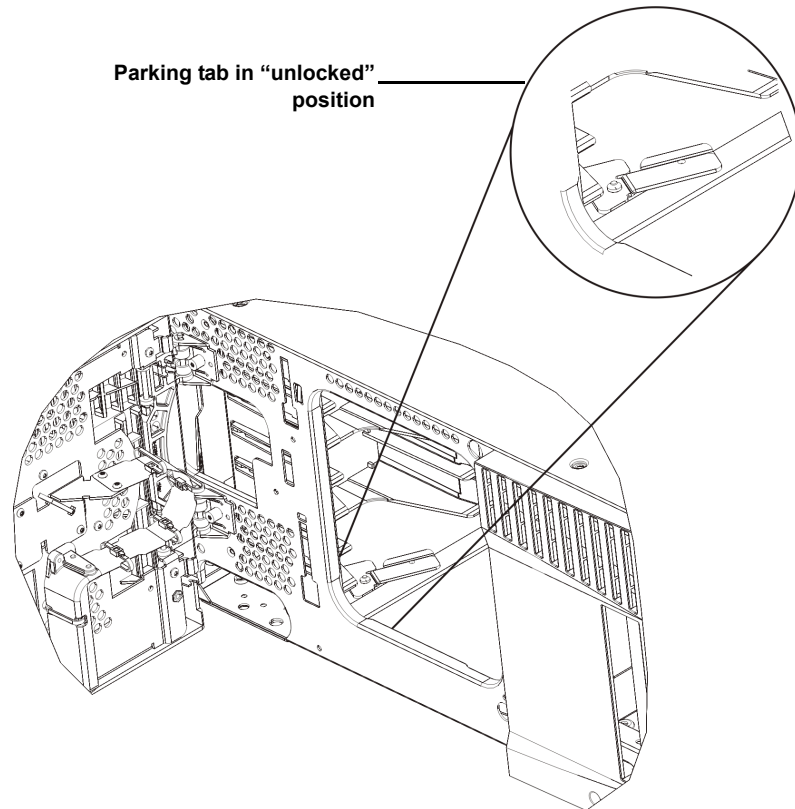

Step 4: Install the Module Components

For instructions on any of the following steps, see the *Scalar i500 User's Guide*.

- 1** If not already installed, install the library control blade (LCB) in the control module.
- 2** Install the tape drives.
- 3** Install the power supplies.
- 4** Install the Fibre Channel (FC) I/O blade (if required and not already installed).
- 5** Close the library's I/E station door and access door.

Step 5: Connect the Tape Drive Cables

Follow the instructions below for the type(s) of tape drives installed in your library. The instruction sets are:

- [Connecting Parallel SCSI Cables](#) on page 11
- [Connecting Fibre Channel Cables Directly to Host or Switch](#) on page 13
- [Connecting Fibre Channel Cables Through an I/O Blade](#) on page 14
- [Connecting Serial Attached SCSI \(SAS\) Cables](#) on page 15

A library can have any combination of SCSI, FC, and SAS drives, connected directly to hosts or through I/O blades. You may need to follow more than one set of instructions below. For more detailed instructions, see the *Scalar i500 User's Guide*.

Connecting Parallel SCSI Cables

There are two recommended ways to cable SCSI tape drives: one tape drive per SCSI bus or two tape drives per SCSI bus.

Caution: The library supports a maximum cable length of 12 meters (including internal wiring) for Ultra 160 SCSI and Ultra 320 SCSI cables.

To connect one tape drive per SCSI bus:

- 1 Use a SCSI cable to connect the bottom port of the tape drive to your host system.
- 2 Attach a SCSI terminator to terminate the top port of the tape drive.

To connect two tape drives per SCSI bus:

- 1 Connect one end of the SCSI cable to the top SCSI port of the bottom tape drive. Then connect the other end of the cable to the bottom SCSI port of the tape drive above. To avoid possible performance issues, do not connect more than two tape drives per SCSI bus.

Note: The SCSI cable connecting the two tape drives should be at least 30 cm in length.

- 2 Use another SCSI cable to connect the bottom tape drive of the SCSI bus to your host system.
- 3 Use a SCSI terminator to terminate the top tape drive of the SCSI bus.

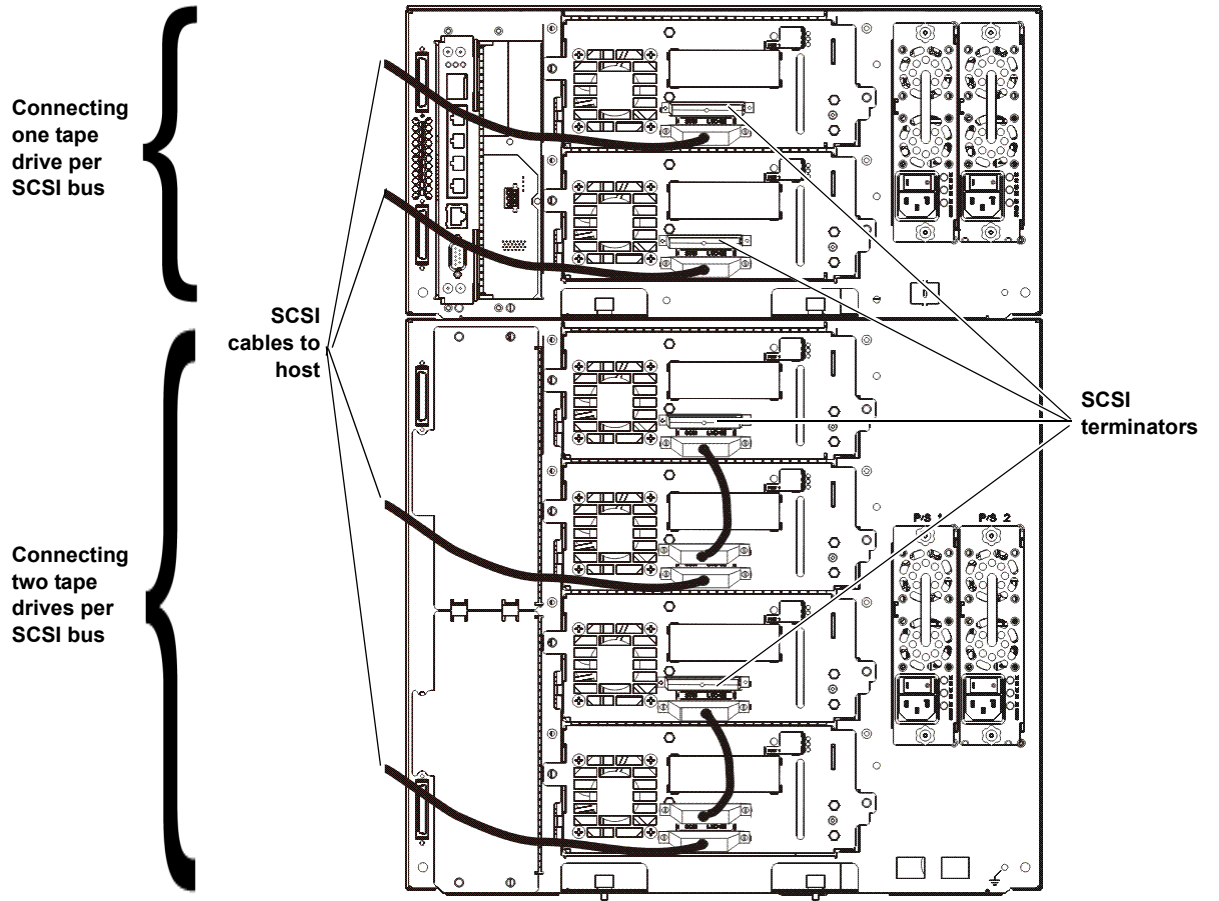

**Connecting Fibre Channel
Cables Directly to Host or
Switch**

For each tape drive:

- 1 Connect one end of a Fibre Channel cable to the Fibre Channel port on the tape drive.
- 2 Connect the other end of the cable to your host or switch.

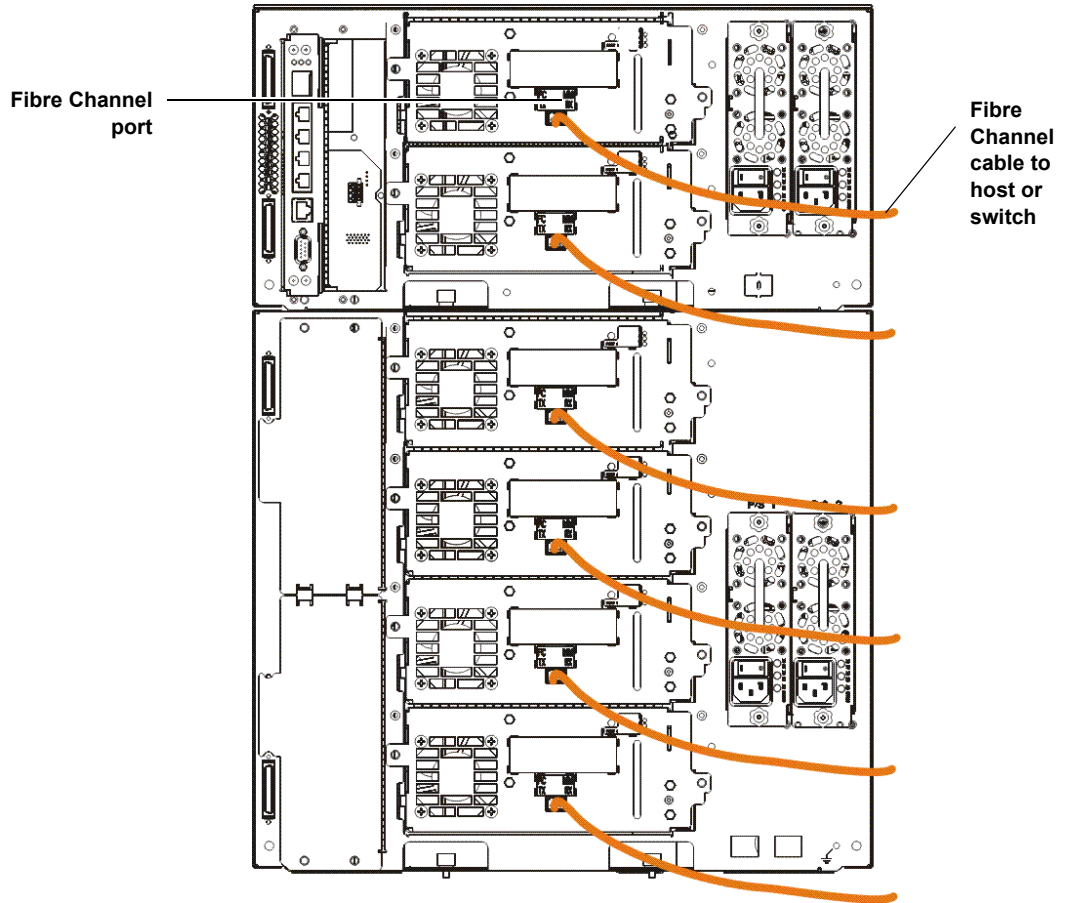

Connecting Fibre Channel Cables Through an I/O Blade

For each tape drive:

- 1 Connect one end of a Fibre Channel cable to the Fibre Channel port on the tape drive.
- 2 Connect the other end of the cable to an initiator port (lower ports 3 - 6) on the nearest Fibre Channel I/O blade.

For each Fibre Channel I/O blade:

- 3 Connect one end of a Fibre Channel cable to one of the target ports (upper ports 1 and 2) on the Fibre Channel I/O blade.
- 4 Connect the other end of the cable to your host or switch.

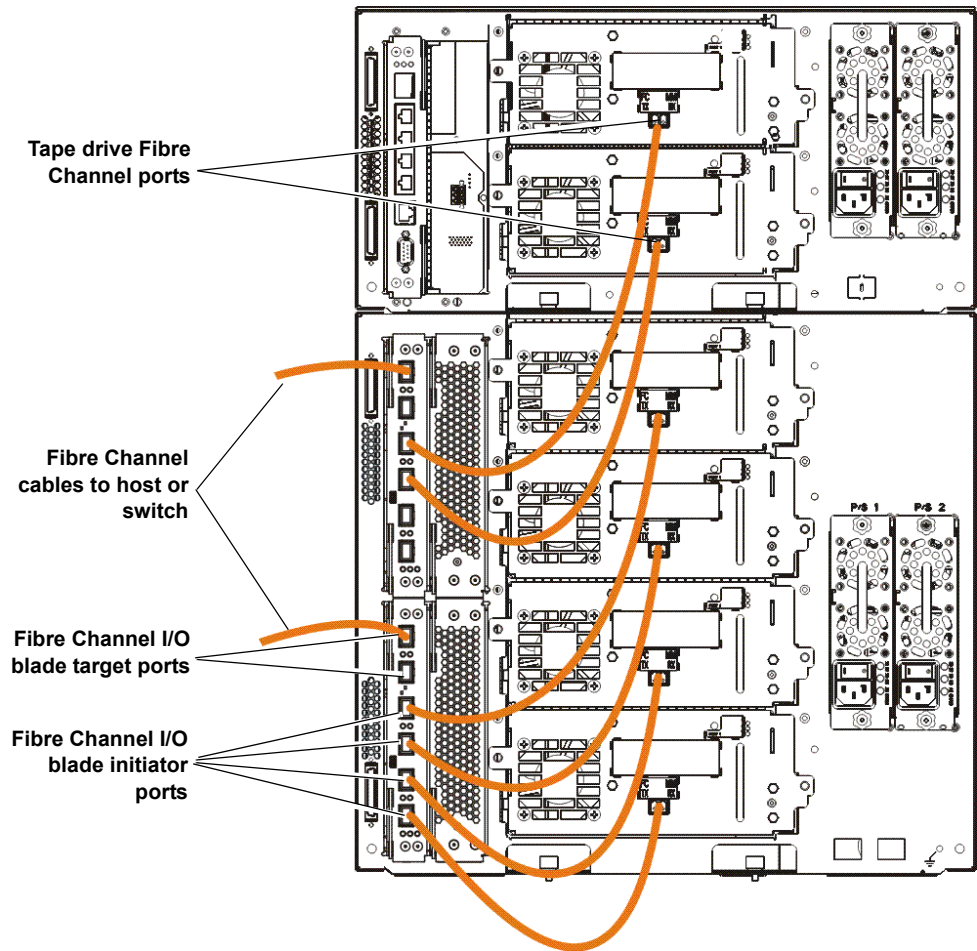

Connecting Serial Attached SCSI (SAS) Cables

For each tape drive:

- 1 Connect one end of a SAS cable to the SAS port on the tape drive.
- 2 Connect the other end of the cable directly to the host.

Caution: The library supports SAS host cable lengths meeting the standard SAS specification.

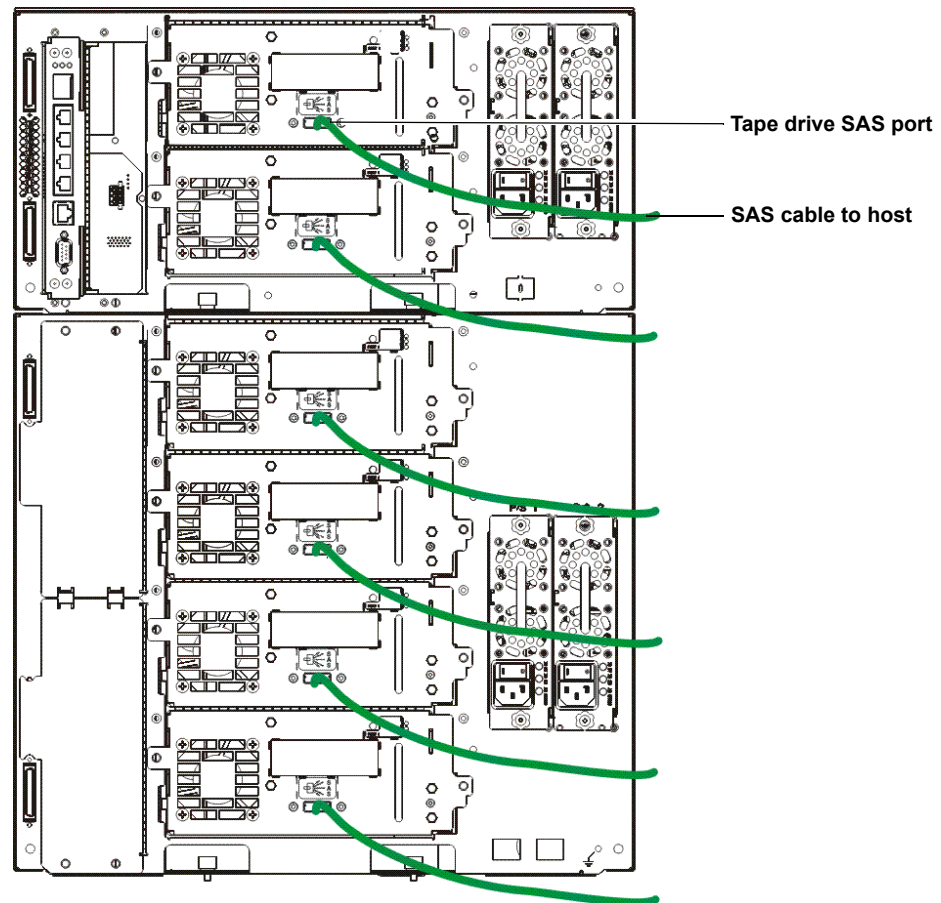

Step 6: Connect the Library Cables

- 1 Remove the protective plastic caps covering the module connectors on the control module and expansion module(s).

- 2 Connect the module cables and module terminators.

All libraries must use module terminators. Libraries that consist of multiple modules must use module-to-module cables.

Caution: The module terminator is not the same as a SCSI terminator. Using a SCSI terminator instead of a module terminator can damage the library. The module terminators are packaged in plastic and secured to the back of the control module by a plastic tie.

- a Using the module-to-module cables from the accessory kit, connect each module to the one above it. Connect one end of the cable to the bottom module. Then connect the other end of the cable to the module above it.
- b Using the module terminators packaged in the plastic bag tied to the back of the control module, terminate the topmost and bottommost modules.

- 3 Connect the library Ethernet cable.

Connect an Ethernet cable to the top Gigabit Ethernet port on the library control blade (LCB) for remote access to the library via the web client. (Ethernet cable not supplied.)

- 4 Connect the module Ethernet cables (if required).

Perform this step if your library contains at least one Fibre Channel I/O blade.

Use Ethernet cables to connect the LCB in the library control module to each expansion module that contains a Fibre Channel I/O blade. For each Fibre Channel I/O blade installed in an expansion module:

- a Connect one end of the Ethernet cable to any of the four middle Ethernet ports on the LCB Ethernet hub. (The uppermost port is for remote access to the library via the web client, and the bottommost port is for service access.)
 - b Connect the other end of the cable to the appropriate port on the 9U Expansion Module. If the Fibre Channel I/O blade is installed in the upper bay, use the port labelled "UPPER." If the Fibre Channel I/O blade is installed in the lower bay, use the port labelled "LOWER."
- 5 Connect the power cords.

At least one power supply is required for each module that contains tape drives.

For each power supply, connect one end of the power cord to the power supply. Then connect the other end to a nearby grounded AC power source (of the type marked on the product label).

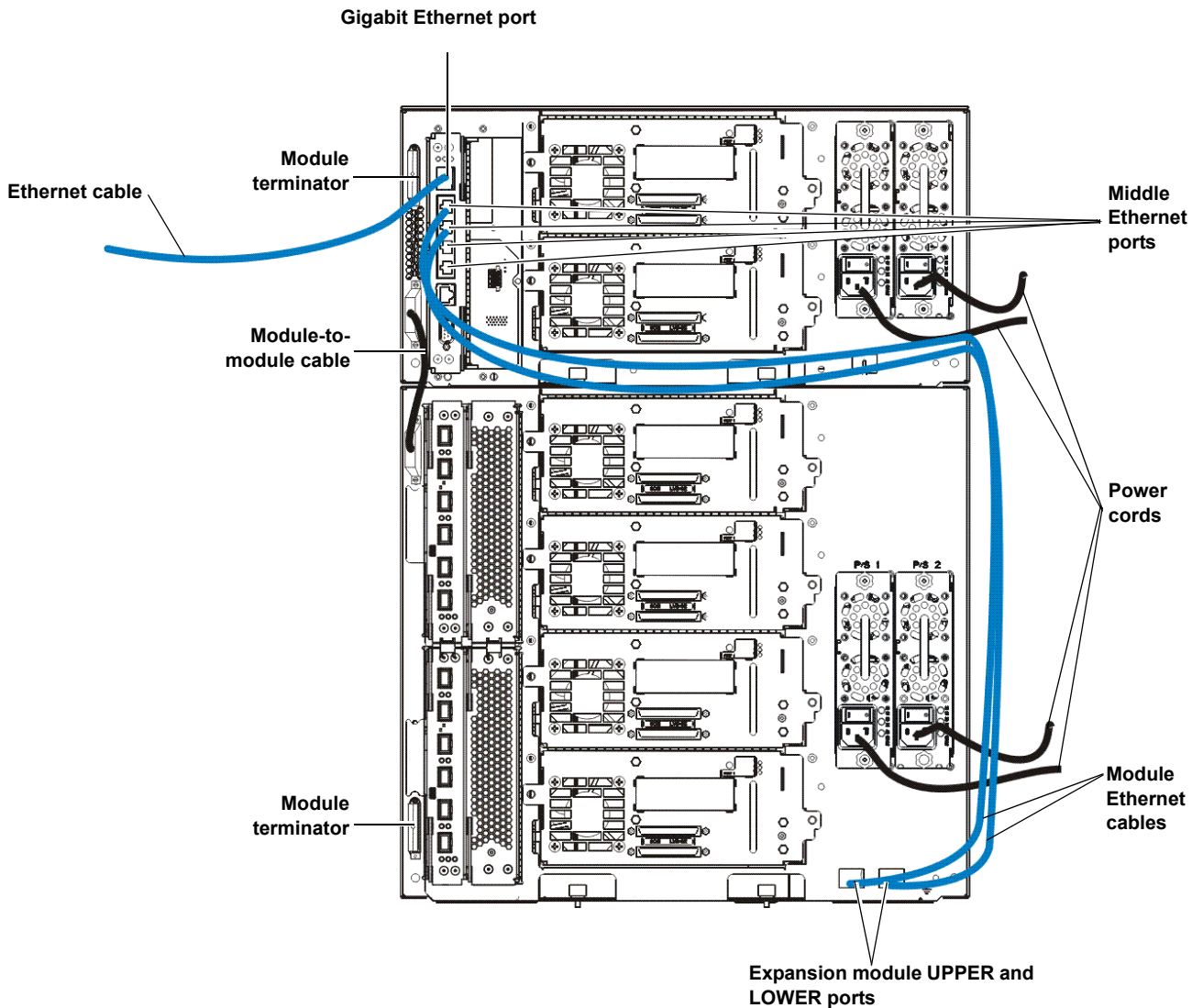

Step 7: Configure the Library Settings

- 1 Power on the library.
 - a Turn on the rear power switch of each of the power supplies.
 - b Press the power switch on the front of the library once.
 - c Power up the host system.
- 2 Verify communication with all devices on the bus.
- 3 Configure the library.

When you first power on the library, the operator panel displays the **Setup Wizard**. The **Setup Wizard** helps you to configure network settings, set the date and time, create user accounts, configure I/E slots, and perform other tasks that allow you to begin using the library. You must start using the **Setup Wizard** on the operator panel. After performing initial configuration, you can continue to use the **Setup Wizard** on the web client.

Note: You may skip initial configuration, or exit partway through. If you do this, the settings you do not configure will be assigned the following default settings until you change them:

- DHCP enabled
- Six I/E station slots
- Zero cleaning cartridge slots
- The library creates partitions and assigns available library resources proportionately among the partitions, grouping tape drives according to distinct combinations of tape drive interface type (SCSI, FC, or SAS) and tape drive vendor.

Note: The operator panel Setup Wizard only appears once, the first time you turn the library on. You cannot log on to the web client until you configure the network settings on the operator panel. If you exit the operator panel Setup Wizard before configuring network settings, you must configure the network settings on the operator panel (**Setup > Network Mgmt**) before logging on to the web client.

The recommended procedure for using the **Setup Wizard** for the initial configuration is as follows:

- a** Turn on the library and begin using the **Setup Wizard** on the operator panel.
- b** The **Setup Wizard** prompts you to enter the network settings that allow the web client to access the library. Be sure to complete this step.
- c** Open the web client using the library's IP address. To view library's IP address, select **Setup > Network Mgmt** from the operator panel.
- d** Log in to the web client using the default administrative account as follows: Type admin in the **User Name** text box and password in the **Password** text box.
- e** Complete the **Setup Wizard** screens on the web client. The final **Setup Wizard** screen will prompt you to apply your settings.

When you have completed the **Setup Wizard**, the Library Configuration report appears on the web client. The Library Configuration report provides information on the library's tape drives, partitions, I/E stations, storage slots, cleaning slots, and loaded media.

If you need additional licenses for storage slots, encryption key management, or advanced reporting, contact technical support. For technical support contact information, visit <http://www.quantum.com/support>.

For detailed instructions on configuring the library, see the *Scalar i500 User's Guide*. See also the library's online Help. To access the online Help system, click the **Help** icon at the top right of the web client or operator panel.

Note: SMI-S is disabled by default. If you want to enable SMI-S, you must manually enable it from the operator panel by selecting **Tools > System Settings > Enable SMI-S**.

4 Load tape cartridges into the library.

For instructions on importing and bulk loading tape cartridges, see the *Scalar i500 User's Guide*.

5 Assign tape drives to partitions (if using the I/E commands).

When manual cartridge assignment is enabled (the default setting), you cannot import cartridges using the I/E commands until you have assigned them to a partition. The Assign IE screen on the operator panel will prompt you to assign them to a partition.

If manual cartridge assignment is disabled, the Assign IE screen does not appear and the cartridges in the I/E station are visible to all partitions, as well as the system partition, and can be used by any partition. For more information, see the *Scalar i500 User's Guide*.

6 Connect to the host application.

Set up the connection to the library host application. If your host application inventories the location of each tape cartridge in the library, open the host application and perform a reinventory to sync the logical inventory with the physical inventory of the library.

For instructions, see your host application documentation.

7 Register the library.

For more information about registering the library, see in the *Scalar i500 User's Guide*.

Step 8: Run the Library

You are now ready to start using your library. For information about using your library, see the *Scalar i500 User's Guide*. See also the library's online Help. To access the online Help system, click the **Help** icon at the top right of the web client or operator panel.

Note: You can download the latest drivers from: www.quantum.com.

Note: The maximum number of expansion modules supported in a library depends on the level of firmware the library is running. The latest firmware must be installed on the library if you are upgrading from a 5U, 14U, 23U configuration to a larger configuration. The latest firmware can be found at www.quantum.com.