

Installation and Operating Guide

Scalar 218M Library



 Advanced Digital Information Corp

Copyright Notice

© Copyright ADIC 1998,1999

The information contained in this document is subject to change without notice.

This document contains proprietary information which is protected by copyright. All rights are reserved. No part of this document may be photocopied, reproduced, or translated to another language without the prior written consent of ADIC.

ADIC shall not be liable for errors contained herein or for incidental or consequential damages (including lost profits) in connection with the furnishing, performance or use of this material whether based on warranty, contract, or other legal theory.

Printed in the USA

August 1999

Document Number 62-0114-01 Rev D

Advanced Digital Information Corporation

Telephone: (425) 881-8004

Fax: (425) 881-2296

World-Wide Web: <http://www.adic.com>

Shipping Address: 11431 Willows Road NE
Redmond, WA 98052

Mailing Address: PO Box 97057
Redmond, WA 98073-9757

ADIC Europe
ZAC des Basses Auges
1, rue Alfred de Vigny
78112 - Fourqueux, FRANCE
Telephone: 33 (0)1 30 87 53 00
Fax: 33 (0)1 30 87 53 01

For Customer Assistance:

In the United States and Canada, call ADIC's Technical Assistance Center at: (800) 827-3822

In Europe, call ADIC's Technical Assistance Center at: 00.800.9999.3822

ADIC™ and ADIC Europe™ are trademarks of Advanced Digital Information Corporation. Exabyte® is a registered trademark and EXB-480™ is a trademark of Exabyte Corporation. Quantum® is a registered trademark and DLT™ is a trademark of Quantum Corporation.

Copyright Notice (Europe)

© Copyright ADIC Europe 1998, 1999

All rights reserved. No part of this document may be copied or reproduced in any form or by any means, without prior written permission of ADIC Europe™, ZAC des Basses Auges, 1, rue Alfred de Vigny, 78112 - Fourqueux, FRANCE.

ADIC Europe assumes no responsibility for any errors that may appear in this document, and retains the right to make changes to these specifications and descriptions at any time, without notice.

This publication may describe designs for which patents are pending, or have been granted. By publishing this information, ADIC Europe conveys no license under any patent or any other right.

ADIC Europe makes no representation or warranty with respect to the contents of this document and specifically disclaims any implied warranties of merchantability or fitness for any particular purpose. Further, ADIC Europe reserves the right to revise or change this publication without obligation on the part of ADIC Europe to notify any person or organization of such revision or change.

Every effort has been made to acknowledge trademarks and their owners. Trademarked names are used solely for identification or exemplary purposes, any omissions are made unintentionally.

EMI/RFI Compliance

United States – FCC

WARNING: This equipment has been tested and found to comply with the limits for a Class B digital device, pursuant to Part 15 of the FCC Rules. These limits are designed to provide reasonable protection against harmful interference in a residential installation. This equipment generates, uses, and can radiate radio frequency energy and, if not installed and used in accordance with the instructions, may cause harmful interference to radio communications. However, there is no guarantee that interference will not occur in a particular installation. If this equipment does cause harmful interference to radio or television reception (which can be determined by turning the equipment off and on) the user is encouraged to try to correct the interference by one or more of the following measures:

- Re-orient or relocate the receiving antenna.
- Increase the separation between the equipment and receiver.
- Connect the equipment into an outlet on a circuit different from that to which the receiver is connected.
- Consult the dealer or an experienced radio/TV technician for help.

You may find the following booklet prepared by the Federal Communications Commission helpful: *How to Identify and Resolve Radio-TV Interference Problems*. This booklet is available from the US Government Printing Office, Washington, DC 20402, Stock No. 004-000-00354-04.

Any changes or modifications not expressly approved by ADIC could void the user's authority to operate this equipment.

Canada – Department of Communications

This digital apparatus does not exceed the Class B limits for radio noise emissions from digital apparatus as set out in the interference-causing equipment standard entitled "Digital Apparatus", ICES-003 of the Department of Communications.

Cet appareil numérique respecte les limites de bruits radioélectriques applicables aux appareils numériques de Class B prescrites dans la norme sur le matériel brouilleur: "Appareils Numériques", NMB-003 édictée par le ministre des Communications.

Shielded Cables

Shielded data cable(s) are required in order to meet EMI/RFI limit specifications. The ADIC data cable meets this requirement. If you need a replacement cable, be sure to use an ADIC-approved shielded cable (to assure acceptability to EMI/RFI requirements).

DECLARATION OF CONFORMITY

according to EN 45014

Manufacturer's Name: Advanced Digital Information Corporation
Manufacturer's Address: 11431 Willows Road ZAC des Basses Auges
Redmond, Washington 1, rue Alfred de Vigny
98052 78112 Fourqueux,
U.S.A. France

declares, that the product:

Product SCALAR 218
(Produit, Erzeugnis):
Model Numbers 218
(Marque Commercial, 218M
Warenbezeichnung):

conforms to the following international standards,

Emissions: EN 50081-1, EN 55022 Class B
Immunity: EN 50082-1:1995
Safety: EN 60950
Quality: ISO 9001

Supplementary Information:

Signature: _____	Signature: _____
Full Name: _____	Full Name: _____
Position: _____	Position: _____
Date: _____	Date: _____
Place: Redmond, WA USA	Place: Fourqueux, France

Blank Page

Table of Contents

Copyright Notice	ii
Copyright Notice (Europe).....	iii
EMI/RFI Compliance	iv
Safety	ix
Chapter 1 The Scalar 218M Library.....	1
Features	3
Options	4
Chapter 2 Getting Started.....	5
Requirements.....	6
Unpacking and Inspecting.....	6
Checking the Accessories.....	7
Preparing the Library for Installation	7
Removing the Shipping Bracket.....	8
Prepare and Install the Data Cartridges	9
Setting the SCSI IDs	11
Preparing the Host Computer System	12
Power Off the Computer	12
Confirm and/or Install the SCSI Host Interface.....	12
Backup Software	12
Chapter 3 Connecting the Scalar 218M Library.....	13
Installing SCSI Cables, Jumpers and Terminators	14
Determining Your SCSI Configuration	14
Powering on the System	15
Installing the Backup Software	16
Chapter 4 Equipment Description	17
Front Panel Switches and Indicators	18
Rear Panel Switches and Connectors	20
Off-Line Mode Menus	21
Configuration Menu	22
Diagnostics Menu.....	27
Write Flash Memory.....	28
Serial Dnld Flash.....	28
Chapter 5 Operation and Maintenance	29
Normal Operations	30
General Guidelines.....	30
Power Up Checks	30
Drive Power-on Self-Test.....	30
Drive Operating Conditions	32
DLT Media.....	34
Opening the Sliding Access Panel.....	35
Using the Mailbox.....	36
Manually Loading/Unloading Cartridges to/from the Storage Slots (Bulk Loading).....	37
Normal Maintenance	37

Cleaning the Drive Head	37
Cleaning the Enclosure	39
Chapter 6 Troubleshooting and Diagnostics	41
Installation Problems	42
Library and Drive Operational Problems	42
Library Error Codes	43
Environmental Considerations	43
When You Call the ADIC Technical Assistance Center	44
Appendix A Diagnostics Menu	45
Appendix B Error Codes	57
Appendix C Scalar 218M Rack-Mount Installation	61
Appendix D Glossary	69
Appendix E Specifications	73
Index	75

Safety

Warnings

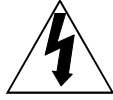

This symbol should alert the user to the presence of "dangerous voltage" inside the product that might cause harm or electric shock.

CAUTION

**RISK OF ELECTRIC SHOCK
DO NOT OPEN**

CAUTION : TO REDUCE THE RISK OF ELECTRIC SHOCK, DO NOT REMOVE COVER (OR BACK). NO USER-SERVICEABLE PARTS INSIDE. REFER SERVICING TO QUALIFIED SERVICE PERSONNEL.

Caution

All safety and operating instructions should be read before this product is operated, and should be retained for future reference. This unit has been engineered and manufactured to assure your personal safety. Improper use can result in potential electrical shock or fire hazards. In order not to defeat the safeguards, observe the following basic rules for its installation, use and servicing.

Warning

The Scalar 218M weighs over 70 lbs. when equipped with two drives. **Do Not** attempt to lift the Scalar out of the packing box, or off of a work surface, by yourself. To avoid personal injury and possible damage to the equipment, two people are required when unpacking, lifting and moving the unit.

- Heed Warnings - All warnings on the product and in the operating instructions should be adhered to.
- Follow Instructions - All operating and use instructions should be followed.
- Ventilation - The product should be situated so that its location or position does not interfere with proper ventilation.
- Heat - The product should be situated away from heat sources such as radiators, heat registers, furnaces, or other heat producing appliances.
- Power Sources - The product should be connected to a power source only of the type directed in the operating instructions or as marked on the product.

-
- Power Cord Protection - The AC line cord should be routed so that it is not likely to be walked on or pinched by items placed upon or against it, paying particular attention to the cord at the wall receptacle, and the point where the cord exits from the product.
 - Object and Liquid Entry - Care should be taken to insure that objects do not fall and liquids are not spilled into the product's enclosure through openings.
 - Servicing - The user should not attempt to service the product beyond that described in the operating instructions. All other servicing should be referred to qualified service personnel.

Precautions

- Do not use oil, solvents, gasoline, paint thinners or insecticides on the unit.
- Do not expose the unit to moisture, to temperatures higher than 60°C (140°F) or to extreme low temperatures.
- Keep the unit away from direct sunlight, strong magnetic fields, excessive dust, humidity and electronic/electrical equipment, which generates electrical noise.
- Hold the AC power plug by the head when removing it from the AC source outlet; pulling the cord can damage the internal wires.
- Use the unit on a firm level surface free from vibration, and do not place anything on top of unit.

Chapter 1

The Scalar 218M Library

This Chapter ...

- provides a brief overview of the Scalar 218M features. For detailed specifications, see Appendix E.

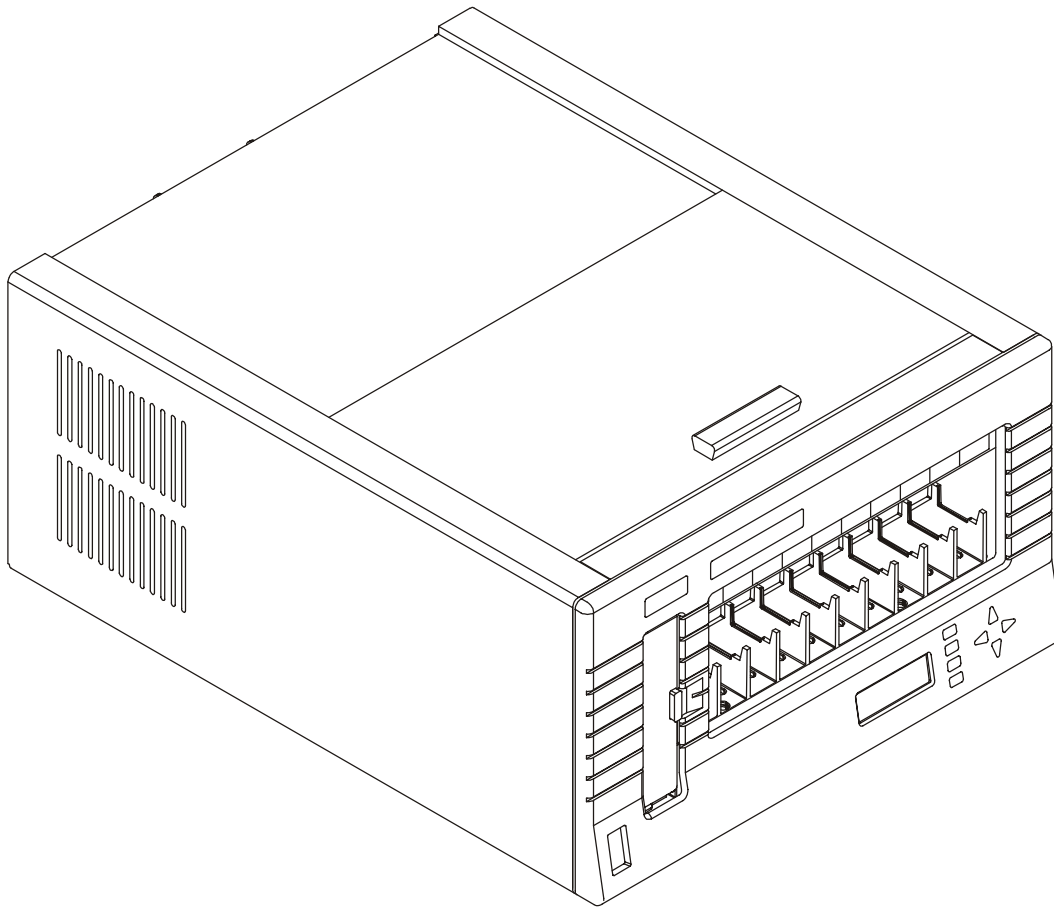

Welcome to your new ADIC Scalar 218M. Your library is a fully automated, high-performance, high-capacity, mass storage system. The Scalar 218M provides you with unattended, near-line and off-line data storage, archiving, backup, hierarchical storage management (HSM), and retrieval for mid-range and high-end servers and networks.

The Scalar 218M is a SCSI-2 compliant library system incorporating streaming tape cartridge data storage devices that feature high capacity, high throughput, and data compression. When equipped with the maximum two Digital Linear Tape (DLT) drives, your library operates as three independent SCSI devices that can be connected to as many as three SCSI buses. Your library can contain up to 18 data cartridges providing a maximum formatted capacity of 1.44 TB and a sustained data transfer rate as high as 1440 MB per minute at an average compression of 2:1 (when equipped with two drives). The tape media, rated at up to 1,000,000 passes and a shelf life of 30 years, provides superior media durability and data reliability.

Features

- **Desktop and Rack-Mounted** units. The Scalar 218M is the first desktop unit to offer over 1 TB of data storage, and its attractive case looks great in any office environment. The more utilitarian rack-mounted unit includes all of the features of the desktop unit, but comes equipped with built-in hardware to allow simple installation into standard 19-inch racks.
- **Multi-function Operator Panel.** The Operator Panel, located at the bottom-right corner of the front panel, employs a 4-line by 20-character liquid crystal display (LCD) and an eight-key keypad to permit you to monitor and control the operations of your library.
- **Media Picker.** The uniquely designed Media Picker is the media cartridge handling mechanism and normally responds to commands from the application software to move the cartridges between the storage slots and the drives. The Media Picker employs a bi-directional, pass-through gripper that will pick a cartridge from both the front of the picker, or the back.
- **Mailbox.** The firmware-configurable single-slot Mailbox, located on the front panel, allows you to insert and remove cartridges from your library without opening the sliding access panel. When configured with a Mailbox slot, there are 17 storage slots available for data cartridges in the Scalar 218M. This reduces the maximum data capacity to 1.36 TB.
- **Barcode Scanner.** The integrated Barcode Scanner reads cartridge information contained in a barcode label attached to each of the data cartridges. This information becomes part of the application software's library cartridge inventory.
- **Exabyte® Emulation.** To maximize application software compatibility, your ADIC library provides functional emulation of the Exabyte EXB-480™ library and can appear as either a Scalar or an Exabyte EXB-480.
- **System Integrity.** A physically-lockable sliding access panel on the top of the Scalar 218M protects the cartridge slots, drives, and robotics. The application software can enable or disable system security. Additionally, the application software can set a logical system lock.
- **Maintainability.** The transparent window on the front panel allows you to view the full operation of your library. If a problem occurs, it is both visible and readily correctable. Your library will report any condition that causes a cartridge load or unload to fail, by displaying an appropriate message on the Operator Panel LCD.
- **Cleaning Cartridge.** Although the cleaning cartridge can occupy a cartridge storage slot in the Scalar 218M (facilitating automated cleaning cycles), you may manually insert a cleaning cartridge through the Mailbox or the sliding access panel.
- **Manual Cartridge Use.** You may easily transport individual cartridges to the drives using the Mailbox slot, or through the sliding access panel.
- **Cartridge Pre-Check.** Whenever you power up, your Scalar 218M maps all cartridge locations. With barcode scan enabled, the barcode reader will scan the barcode label on each cartridge and build a log of barcode labels for each cartridge location.
- **Downloadable Firmware.** Both your Scalar 218M and the DLT drive employ Flash EEPROM technology permitting easy on-site installation of firmware updates from the host computer.

- **Built-in Diagnostics.** Diagnostic firmware tells you when it is time to clean the drive. It also reports diagnostic results, and drive operating status. Embedded data logging of operational and drive errors can aid you in failure analysis.

Options

DLT Drives

You may equip your Scalar 218M library with third- or fourth-generation DLT drives. The DLT4000 and DLT7000 drive models read and write 2.6 GB, 6.0 GB, 10.0 GB, and 15.0 GB tape formats, providing 100% interchange compatibility with earlier DLT drives. The DLT8000 drive model reads and writes 10.0 GB, 15.0 GB, 20.0 GB, and 35.0 GB tape formats for compatibility with the DLT2000, DLT2000xt, DLT4000, and DLT7000 drives. You may select tape density through the application software or by pressing a button on the drive.

DLT Drive	Cartridge		Library (2 drives)	
	Maximum Capacity (avg. 2:1 compression)	Model	Maximum Capacity (avg. 2:1 compression & Mailbox disabled)	Sustained Transfer Rate (avg. 2:1 compression)
4000	20 GB	DLTtape III	360 GB	360 MB/min
	30 GB	DLTtape IIIXT	540 GB	
	40 GB	DLTtape IV	720 GB	
7000	20 GB	DLTtape III	360 GB	1200 MB/min
	30 GB	DLTtape IIIXT	540 GB	
	70 GB	DLTtape IV	1260 GB	
8000	20 GB	DLTtape III	360 GB	1440 MB/min
	30 GB	DLTtape IIIXT	540 GB	
	80 GB	DLTtape IV	1440 GB	

Maximum Capacity and Sustained Transfer Rates

High Voltage Differential SCSI

Your DLT drives and robotics interface are high voltage differential (HVD) SCSI.

Caution

HVD and Single-ended (SE) or Low Voltage Differential/Single-Ended (LVD/SE) SCSI devices are not compatible. Equipment damage may occur if you connect your Scalar 218M library to a SE or LVD/SE SCSI bus.

Chapter 2

Getting Started

This Chapter ...

- covers what you need (and what you need to know) to install your Scalar 218M. Read this chapter before you begin installation.

Installation of the desktop unit requires checking all necessary SCSI connections, loading application software on the host computer, and applying power. Installation of the rack-mount unit begins by mounting slide rails, a cable channel, and channel stop to your rack before continuing the installation.

Requirements

- The footprint of your Library is 19.0 inches wide, 24.5 inches deep, and 10.5 inches high. You must allow clearance at the rear and sides of the desktop unit for airflow and enough room at the top to permit you to bulk load and unload data cartridges through the sliding access panel. To bulk load and unload cartridges from the rack-mount unit, you must slide the library from the rack to the stop limits of the rails. There must be adequate clearance above it to perform the bulk load/unload procedure.
- You must integrate your Scalar 218M into your host computer system. Backup software and a Host Bus Adapter interface card must be purchased separately.
- Necessary tools: to install the rack-mount unit, you will need the following tools.
 - #1 phillips screwdriver.
 - 11/32-inch hex nutdriver.

Unpacking and Inspecting

Warning

The Scalar 218M weighs more than 70 pounds. ***Do Not*** attempt to lift the Library out of the packing box by yourself.

- Save the packing materials in case you need to move or ship the system in the future.

Caution

You must use the original, or equivalent packing materials, when shipping the Scalar 218M. Failure to use the original or equivalent materials may invalidate your warranty.

Checking the Accessories

Check to make certain that the following items are included with your Scalar 218M:

- Power cord
- * One DLTtape IV data cartridge
- * One cleaning cartridge, or a coupon for a free DLT cleaning cartridge
- * One Adaptec Host Bus Adapter (Adaptec model AHA 2944UW), differential SCSI controller
- * One 68-pin, differential, SCSI terminator
- * One 15' HD68/HD68 SCSI cable
- * One 2' HD68/HD68 SCSI cable
- * One 1' HD68/HD68 SCSI jumper cable
- Barcode labels
- This Scalar 218M Installation and Operating Guide
- A Warranty Registration card
- Two keys for the sliding access panel lock (desktop unit only), or the slam-lock (rack-mount unit only)
- One cable channel (rack-mount unit only)
- One channel stop (rack-mount unit only)
- Two outer rails (rack-mount unit only)
- Mounting hardware (rack-mount unit only)
- ✓ None of the items should show signs of damage.
- * Certain Scalar 218M configurations only.

Preparing the Library for Installation

Caution

If the operating environment differs from the storage environment by 15° C (30° F) or more, let the unit acclimate to the surrounding environment for at least 12 hours.

Rack-mount Scalar 218M

Complete instructions for installing the rack-mount Scalar 218M are in Appendix C of this manual. After mounting the unit in your rack, return to this section to complete the installation process.

Removing the Shipping Bracket

A shipping bracket holds the Media Picker in place. Remove this bracket before powering-on the unit. Follow the instructions below to remove the shipping bracket.

Desktop Scalar 218M

- Remove the keys taped to the rear panel of your library, and unlock the sliding access panel. The lock is located in the top-right corner of the front panel.
- Using the handle, open the access cover fully by pushing it towards the rear of the Scalar 218M.

Rack-mount Scalar 218M

- Remove the keys taped to the rear panel of your library, and unlock the front panel. Slide it towards you until the slide stops engage.

All Scalar 218M Units

- Inside the Scalar 218M cartridge storage bay, locate the red shipping bracket mounted on the floor.
- Remove the wing nuts that secure the shipping bracket to the floor.

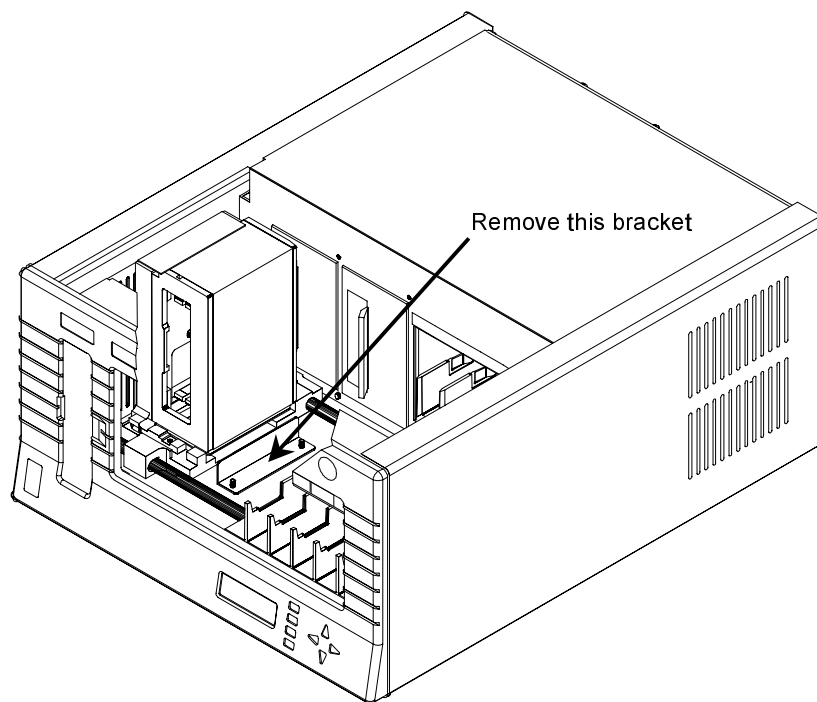

Removing the Shipping Bracket (Desktop Scalar 218M shown)

- Pull the shipping bracket off the studs and remove it from the Scalar 218M.
- Remove the packing foam located between the left chassis wall and the Media Picker.

Prepare and Install the Data Cartridges

Barcode Labels

To install the barcode labels, position the label with the numbers upright, as shown in the illustration below, sliding the label under the ridges on the sides of the cartridge recess.

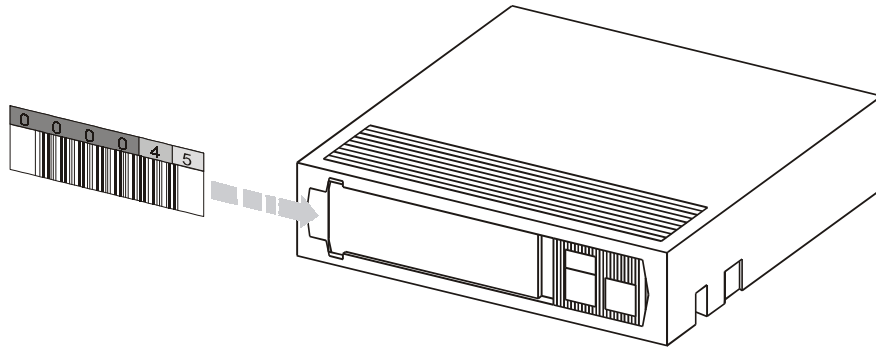

Barcode Labels

Write-Protect Switch

Set the write-protect switch (see illustration below) on each cartridge to the appropriate position. Use your finger to push the switch in one of the directions shown in the following illustration.

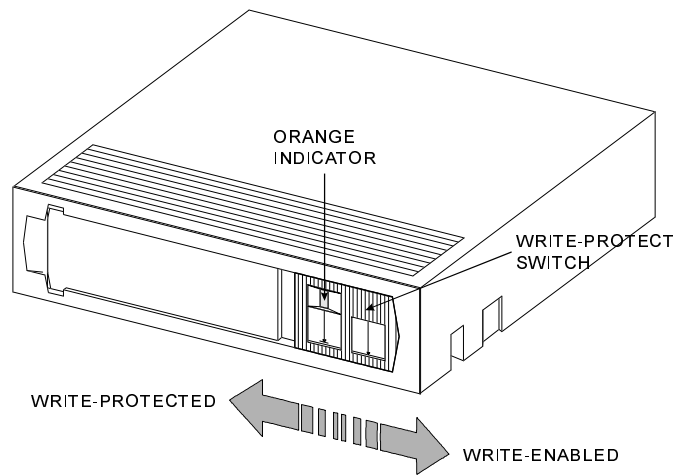

DLT Cartridge Write-Protect Switch

Install Data Cartridges

Desktop Scalar 218M

- ❑ If necessary, unlock the sliding access panel by placing the key in the lock, and turning it ½ turn counter clockwise (left) to unlock.
- ❑ Open the sliding access panel by sliding it to the rear of the Scalar 218M.

Rack-mount Scalar 218M

- ❑ If necessary, unlock the front panel and slide it towards you until the slide stops engage.

All Scalar 218M Units

- ❑ Place each of the cartridges into the library storage slots. Install all cartridges with the barcode label facing forward and the write-protect switch at the top.

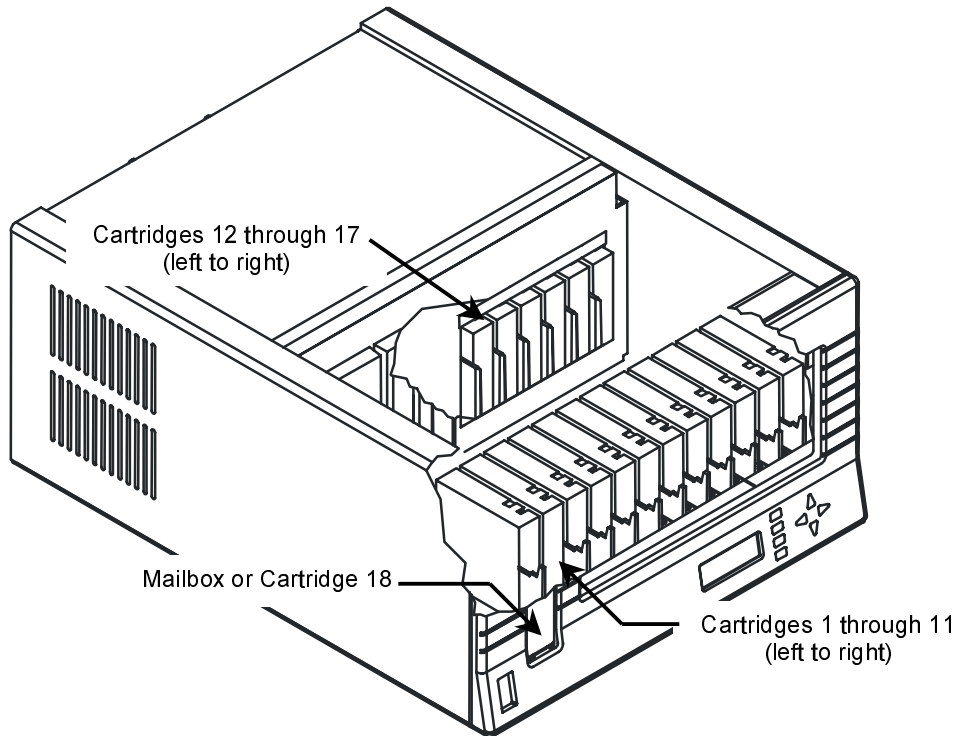

Cartridge Locations

Note

The design of the six rear slots and the Mailbox slot prevents you from incorrectly installing the cartridges. When powered-on, the Scalar 218M senses the orientation of each cartridge installed in the 11 front slots. The library will sound the error alarm and display a message on the LCD warning of any incorrectly installed cartridges in these slots.

Install Cleaning Cartridge (Optional)

If your backup software is capable of scheduling and performing a drive cleaning cycle automatically, you may want to dedicate a cartridge storage slot to a cleaning cartridge. After using all cleaning cycles, remove the cleaning cartridge and install a new one. Refer to *Chapter 5: Operations and Maintenance*, section *Cleaning the Drive Head*, for information on determining when a new cleaning cartridge is needed.

Close and Lock the Sliding Access Panel or Scalar 218M

- On the desktop Scalar 218M, close the sliding access panel by sliding it forward.
- Insert the key into the front panel lock and turn ½-turn clockwise to lock the sliding access panel in place.
- Remove the key from the lock.
- On the rack-mount Scalar 218M, slide the Scalar back into the rack until the slam-lock engages.
- Insert the key into the slam-lock and turn ½-turn clockwise to lock the Scalar into the rack.
- Remove the key from the lock.

Setting the SCSI IDs

Your Scalar 218M consists of up to three SCSI devices; two drives and the library robotics. You can connect the devices to one SCSI bus, or as many as three separate SCSI buses. Set each device in your library to a unique ID. The ID for the robotics is set through the Operator Panel, Off-Line Mode, Configuration Menu, Set SCSI ID option. Refer to subsection *Set SCSI ID*, subsection *Configuration Menu*, section *Off-Line Mode Menus* in *Chapter 4: Equipment Description* of this manual.

- Set the SCSI ID for each drive using the ID switch on the back of the drive assembly.

Note

Individual devices may have the same SCSI ID only when connected to separate SCSI buses.

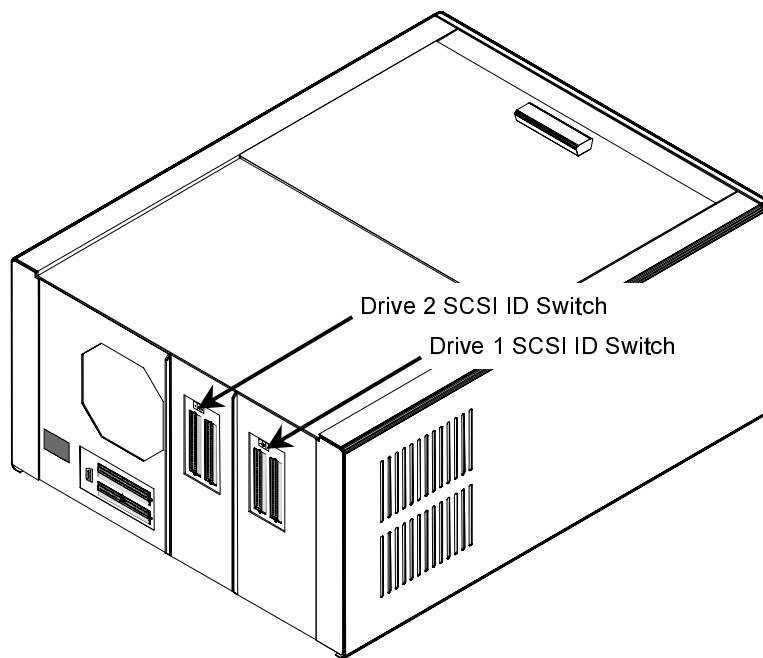

Drive SCSI ID Switches

Preparing the Host Computer System

Power Off the Computer

- Turn off the power switch.
- Unplug the cord from the AC outlet.

Confirm and/or Install the SCSI Host Interface

Your Scalar 218M must be connected to either an integrated SCSI host or a SCSI interface (host adapter) card installed in the computer – either directly to the I/O connector on the card or as part of an existing SCSI chain. Install the SCSI interface before connecting the library. Refer to the instructions supplied with your selected SCSI interface.

Backup Software

A variety of backup and data storage software is available for use with your Scalar 218M. Please check with ADIC Sales or Customer Assistance if you have a question on the compatibility of a particular software package.

Now you are ready to connect the Scalar 218M to your host computer. Follow the instructions provided in the next chapter.

Chapter 3

Connecting the Scalar 218M Library

This Chapter ...

- provides instructions for physically connecting your Scalar 218M to your host system.
- steps you through the final phase of the installation process.

Installing SCSI Cables, Jumpers and Terminators

Follow the steps on the following pages to connect your Scalar 218M to the SCSI bus. This involves installing SCSI cables, terminators and jumpers (daisy chain cables) onto the SCSI connectors at the rear of the Scalar 218M.

Notes

- Assure that the interface cable(s) you are planning on using has the appropriate connectors on each end. You will need to obtain an adapter or a different cable if the SCSI connector(s) on your host computer and that on your Scalar 218M are different. Consult your dealer or the ADIC Technical Assistance Center if you need help.
- The interface cable(s) must be shielded – ADIC can supply you with the correct type(s).

Determining Your SCSI Configuration

The Scalar 218M consists of up to three SCSI devices; two drives and the robotics. Listed below are the SCSI configurations supported by the Scalar 218M:

- The drives in your Scalar 218M are both HVD and must be connected to HVD SCSI buses.

Notes

- SE SCSI devices and HVD SCSI devices **are not** compatible. Do not connect them to the same SCSI bus.
- Use a passive terminator designed for a HVD bus to terminate the bus(es) the drive(s) are connected to.

- You may connect each tape drive and the robotics to separate SCSI buses, or all three devices to the same SCSI bus.
- Connection of a device (drive or robotics) to more than one SCSI bus is allowed when integrated into a multi-initiator environment.
- All termination must be external. Never use internal terminators to terminate the drives.

Note

Your Scalar 218M robotics interface provides SCSI bus TERM POWER, not the drives. If you wish to modify this please call ADIC's Technical Assistance Center (ATAC).

- Check that the power switches are off on your Scalar 218M and your host computer.

-
- Attach one end of the SCSI interface cable(s) to the connector(s) shown on the rear of your Scalar 218M. Press firmly, then tighten the jackscrews on the high-density (68-pin) connector or secure the bail locks on any low-density (50-pin) connectors.
 - Plug the other end of the SCSI interface cable(s) into the external connector(s) on the SCSI interface card(s). Tighten the jackscrews on the high-density (68-pin) connectors.

Note

Securely fasten the jackscrews at both ends of the SCSI cable(s) so your library can communicate properly with the computer.

- Install an external terminator(s) on the appropriate spare SCSI connector(s) on the rear of your Scalar 218M. Securely tighten the jackscrews on the terminator(s).

Powering on the System

- Plug the power cord into the back of your Scalar 218M.
- Plug the power cord from the Scalar 218M into a grounded electrical outlet.

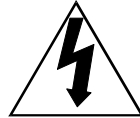

**Use caution when plugging the power cord into an electrical outlet.
Hazardous voltages are present in the sockets of the outlet.**

- Plug the power cord from your host computer into a grounded electrical outlet.
- Turn on power to the Scalar 218M.
- Turn on power to the host computer.

The following illustration shows the Operator Panel LCD message displayed when the library has completed the boot and initialization process.

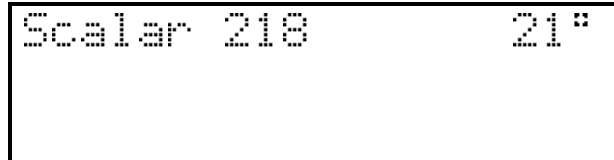

```
Scalar 218                21''
```

Notes

- With the factory *default conditions unchanged*, the library will sign-on as a Scalar 218.
- The Scalar 218M displays the current internal temperature (in *degrees centigrade*) of the library. Whenever the internal temperature *meets or exceeds 40° C*, an alarm will sound and the “safe operating temperature has been exceeded” message will appear on the LCD. The alarm will quit and the message will be removed from the LCD when the temperature falls below 40° C.

You are now ready to install the backup software – if it has not already been installed.

Installing the Backup Software

At this point you need to refer to your software installation guide for instructions on installing the backup and controlling software for the Scalar 218M onto the host computer.

After you have completed installation of the Scalar 218M and of the software, to make sure that your unit is operating correctly, you should run any diagnostic test(s) supplied with the backup software.

After your library and host computer are connected, and the application software installed, the library is ready for use. Just turn on the power switch.

Chapter 4

Equipment Description

This Chapter ...

- describes the switches, indicators and connectors on the front and rear of your Scalar 218M.
- describes the various functions available via the front panel buttons.
- describes the power-up procedure and messages on the front panel LED display.



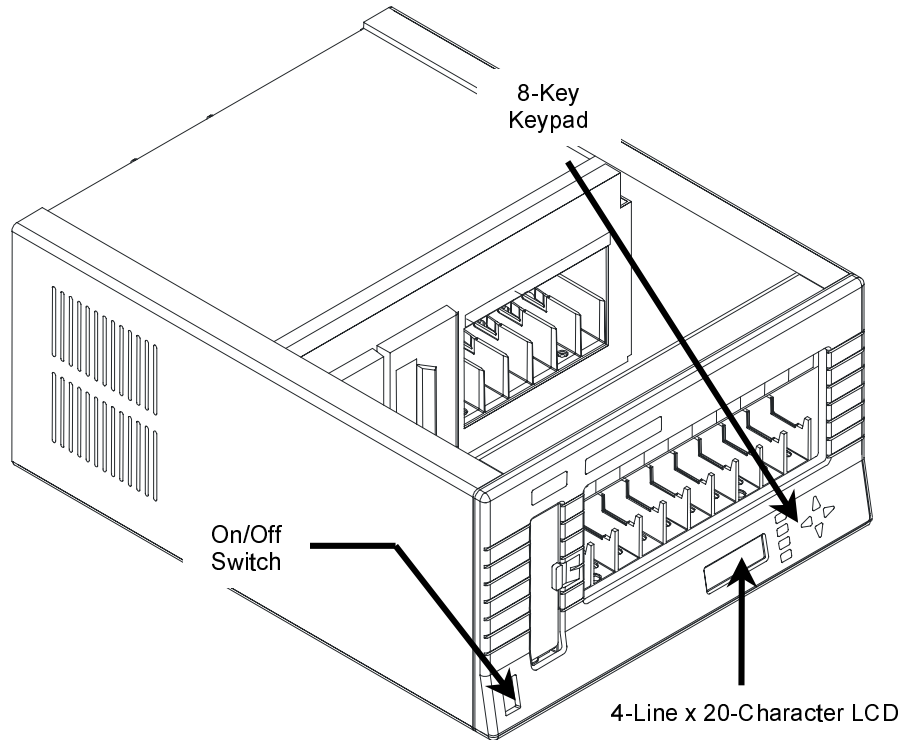

Front Panel Switches and Indicators

The following illustration shows the front panel switches and indicators.



Front Panel of Scalar 218M Library

Front Panel Switches	
On/Off Switch	The power switch turns the Scalar 218M ON and OFF.
MENU	Press this button to enter or exit the Off-Line mode of operation.
ESC	Exits current menu and returns to previous menu.
ALT	Selects alternate function for another button.
ENTER	Selects currently displayed item.

Front Panel Switches	
 (UP)	Selects previous item or value in menu, and moves cursor to previous line.
 (DOWN)	Selects next item or value in menu, and moves cursor to next line.
 (LEFT)	<p>Selects previous field on same line, and scrolls message to the left.</p> <p>When in the On-Line mode of operation, if pressed immediately after the ALT key has been pressed, this key will cause the Picker to move to the extreme right.</p>
 (RIGHT)	<p>Selects next field on same line, and scrolls message to the right.</p> <p>When in the On-Line mode of operation, if pressed immediately after the ALT key has been pressed, this key will cause the Picker to move to the extreme left.</p>

Front Panel Indicators	
LCD	The four-line 20-character LCD shows current drive status of the Scalar 218M Library and allows access to change features or displays error messages.

Rear Panel Switches and Connectors

The following illustration shows the switches and connectors on the rear of the Scalar 218M Library.

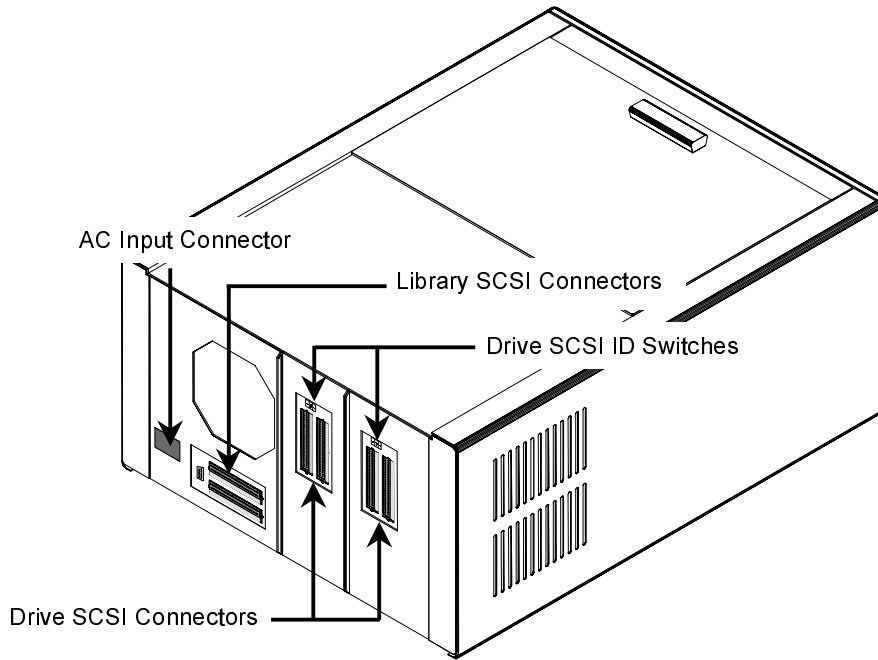

Rear of Scalar 218M

Rear Panel Switches and Connectors	
AC Input Connector	Plug the AC power cord into this connector.
SCSI Connectors	Connections for the interface cable(s), SCSI jumpers, and/or SCSI terminators. Used to connect the Library robotics and drives to the host computer SCSI bus(es) , or to other devices on the SCSI channel.
Drive SCSI ID Switches	Sets the SCSI ID for each drive.

Off-Line Mode Menus

The following diagram is a quick reference to the LCD menus described on the next few pages.

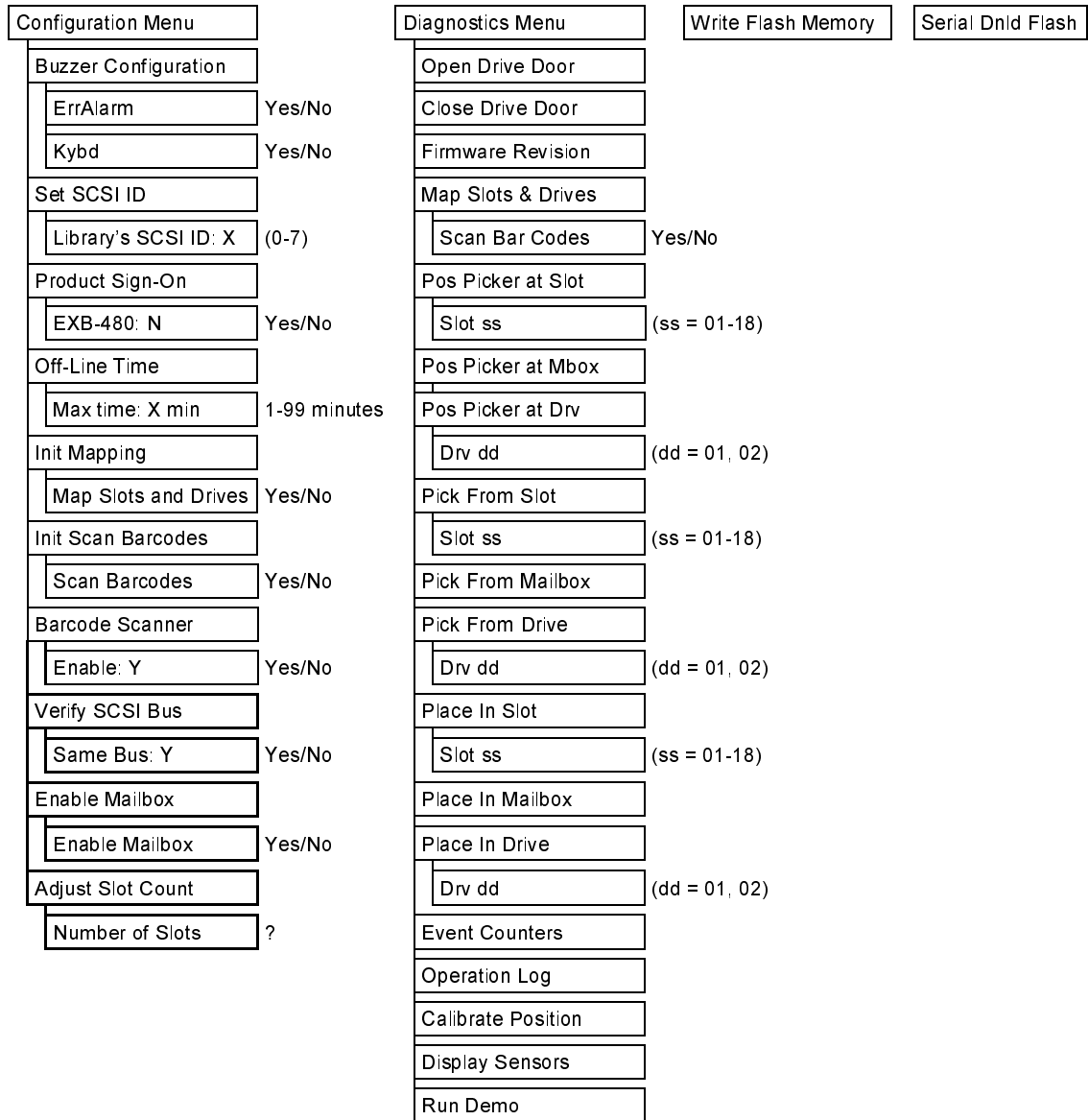



Scalar 218 21°

When powered-on, and after completing the initialization process, the LCD will appear as shown above.

- To access any Off-Line Mode menu, press the **MENU** key. The display will appear as follows:



OFF-LINE MENU
Configuration Menu ▸

- Use the **UP** or **DOWN** keys to scroll through the menu choices. Press **ENTER** to select the item displayed on the top line. Use the **RIGHT** or **LEFT** keys to scroll through fields on the same line.
- To exit any Off-Line Mode menu and return to the On-Line Mode from anywhere in any menu, press the **MENU** key.
- Press **ENTER** to select the Configuration Menu.

Configuration Menu

The Configuration Menu allows you to select the following operating parameters:

- Buzzer Configuration
- Product Sign-On
- Init Mapping
- Barcode Scanner
- Enable Mailbox
- Set SCSI ID (Library Robotics)
- Off-Line Time
- Init Scan Barcodes
- Verify SCSI Bus
- Adjust Slot Count

Buzzer Configuration



BUZZER CONFIGURATION
Err Alarm:N Kbd:Y

Enables/disables the sounding of an alarm when an error message or warning alarm is displayed. Enables/disables the beep sound when you press a keypad key.

- To enable the error alarm use the **LEFT** key to select the ErrAlarm field. Use **UP** or **DOWN** to select "Y" to enable alarm or "N" to disable alarm. When the error alarm is enabled, a continuous alarm tone will sound in the event of an error message. The alarm will sound until the condition that caused the error has been removed or any key is pressed. To clear an error message from the display, press **ALT** and **ENTER**.

-
- If you wish to change the status of the keyboard beep, use the **RIGHT** key to select the Kybd field. Use **UP** or **DOWN** to select "Y" to enable a beep when you press a key or "N" to disable the beep.

Note

BUZZER CONFIGURATION default: Err Alarm: N, Kbd: Y

- Press **ENTER** to make the changes effective or press **ESC** to return to previous menu item.

Set SCSI ID

```
SET SCSI ID
Library's SCSI ID: 5
```

Lets you select the SCSI ID for the robotics on the library.

- Use **UP** and **DOWN** to select the desired ID. Press **ENTER** to execute the change. Confirm the change by pressing **ENTER** again.

Note

SET SCSI ID default is Library's SCSI ID:1.

Product Sign-On

```
PRODUCT SIGN-ON
Sign on "EXABYTE
EXB-480": N
```

Lets you select how the Scalar 218M appears to application software. The library can be set to sign-on as an Exabyte® EXB-480™ library. This permits maximum application software compatibility.

- Use **UP** or **DOWN** to select "Y" or "N". Press **ENTER** to execute the change.

Note

PRODUCT SIGN-ON default is EXB-480: N.

Off-Line Time

```
OFF-LINE TIME
Max. time: 05 min.
```

Lets you set the number of minutes the Scalar 218M will remain in the Off-Line Mode. If someone leaves the library in the Off-Line mode, after the pre-set number of minutes the library will automatically return to On-Line Mode. This assures that your automatic backup will be done even if the library has accidentally been left off-line.

- Use **UP** or **DOWN** to select the number of minutes you wish the Scalar 218M to remain in Off-Line Mode. Press **ENTER** to execute the change.

Note

OFF-LINE TIME default setting is "5" minutes.

Init Mapping

```
INIT MAPPING
Map slots and drives
at initialization: Y
```

Enables/disables the mapping of the storage slots whenever the Scalar 218M is powered-up, after the sliding access panel has been opened and then closed, or if a SCSI bus Reset occurs.

- To disable the mapping of slots use the **UP** or **DOWN** keys to select "N". Press **ENTER** to execute the change.

Note

INIT MAPPING default setting is Y.

Note

Disabling INIT MAPPING by selecting "N" will force INIT SCAN BARCODES to "N" (see below).

Init Scan Barcodes

```
INIT SCAN BARCODES
Scan barcodes at
initialization: Y
```

Enables/disables the scanning of the cartridge barcodes whenever the Scalar 218M is powered-up, or after the sliding access panel has been opened and then closed. The application software overrides the setting of this parameter. If Barcode Scanner configuration is set to No, Initialize Scan Barcodes is ignored, and the barcode reader is not available to the application software.

- To disable the scanning of barcodes use the **UP** or **DOWN** keys to select "N". Press **ENTER** to execute the change.

Note

INIT SCAN BARCODES default setting is Y.

Note

Enabling INIT SCAN BARCODES by selecting "Y" will force INIT MAPPING to "Y" (see above).

Barcode Scanner

```
BARCODE SCANNER
Enable bar code
scanner: Y
```

Enables/disables the barcode scanner. If disabled, the Configuration Menu, Initialize Scan Barcodes parameter (see above), and the Scan Barcodes sub-function of the Diagnostics Menu, Map Slots function (see *Appendix A*), is ignored. If disabled, the barcode scanner *is not* available to the application software.

- To disable the barcode scanner use the **UP** or **DOWN** keys to select "N". Press **ENTER** to execute the change.

Note

ENABLE BARCODE SCANNER default setting is Y.

Verify SCSI Bus

```
VERIFY SCSI BUS
Drives and changer
on same SCSI bus: Y
```

Verifies that the SCSI devices within your Scalar 218M (the library robotics *and* the drives) are connected to a single SCSI channel. Some network operating systems need to know if the Scalar 218M SCSI devices are connected to more than one SCSI channel.

- To verify that the SCSI devices are connected to more than one SCSI channel use the **UP** or **DOWN** keys to select "N". Press **ENTER** to execute the change.

Note

VERIFY SCSI BUS default setting is Y.

Enable Mailbox

```
ENABLE MAILBOX
Enable mailbox: Y
```

Enables/disables the Mailbox as a cartridge input/output element. When your Scalar 218M Mailbox is enabled, there are 17 storage slots available to store data cartridges. The application software will use the Mailbox slot to move cartridges into, and out of the library storage slots. When the Mailbox is disabled, the slot is configured as storage slot number 18 and is available to store a data cartridge.

- To disable the Mailbox, and configure the slot as a storage location, use the **UP** or **DOWN** keys to select "N". Press **ENTER** to execute the change.

Note

ENABLE MAILBOX default setting is Y.

Adjust Slot Count

```
ADJUST SLOT COUNT
Num Slots: 18
```

Adjusts the number of storage slots available to the application. This parameter is dependent upon the setting of the Enable Mailbox parameter (see above). If the Mailbox is disabled, choices are 18 slots or 16 slots. If set for 16

slots, slots 17 and 18 (Mailbox slot) are disabled. If the Mailbox is enabled, choices are 17 slots or 16 slots. If set for 16 slots, slot 17 is disabled. The Adjust Slot Count parameter setting affects the maximum slot available to Pos Picker At Slot, Pick From Slot, and Place In Slot functions available under the Diagnostics Menu. Refer to Appendix A for a detailed description of these functions.

- ❑ To adjust the slot count, use the **UP** or **DOWN** keys to select between "18" or "16" if the Mailbox is disabled, or select between "17" or "16" if the Mailbox is enabled. Press **ENTER** to execute the change.

Note

ADJUST SLOT COUNT default setting is 18 if Mailbox is disabled, and 17 if Mailbox is enabled.

Diagnostics Menu

OFF-LINE MENU
Diagnostics Menu

The following functions are available under the Diagnostics Menu:

- Open Drive Door
- Close Drive Door
- Firmware Revision
- Map Slots & Drives
- Pos Picker at Slot
- Pos Picker at Mbox
- Pos Picker at Drv
- Pick From Slot
- Pick From Mailbox
- Pick From Drive
- Place In Slot
- Place In Mailbox
- Place In Drive
- Event Counters
- Operation Log
- Calibrate Position
- Display Sensors
- Run Demo

For detailed descriptions of these functions, refer to Appendix A.

Note

We strongly recommend that only a qualified service technician use these diagnostic functions. Some diagnostic functions assume the Scalar 218M has been configured correctly and many of the normal built-in safety checks are turned off. Misusing these diagnostic functions without the normal safety checks could result in improper operation (or damage to media and/or the Scalar 218M).

Write Flash Memory

```
OFF-LINE MENU
Write Flash Memory 47
```

The Write Flash Memory mode is used whenever you upgrade the Scalar 218M firmware using the SCSI bus. When ADIC releases new firmware for the Scalar 218M, complete instructions on using Write Flash Memory mode and performing the upgrade will be included with the firmware.

Serial Dnld Flash

```
OFF-LINE MENU
Serial Dnld Flash 4
```

The Serial Dnld (Download) Flash mode is used whenever you upgrade the Scalar 218M firmware using the serial port on the rear panel. When ADIC releases new firmware for the Scalar 218M, complete instructions on using Serial Dnld Flash mode and performing the upgrade will be included with the firmware.

Chapter 5

Operation and Maintenance

This Chapter ...

- describes normal operation features of the Scalar 218M Library
- provides details on the media and drive head cleaning cartridge
- explains normal maintenance procedures

Normal Operations

General Guidelines

Once your Scalar 218M and your choice of application software are installed and configured, you can automatically perform backup and restore operations via the application software. You do not need to intervene unless the application software instructs you to exchange data cartridges through the virtual mailbox slot, or by reaching in through the sliding access panel.

Always follow these general-operating guidelines:

- Open the sliding access panel of the Scalar 218M only when you must. Even if you power down your library, you should keep the door closed to protect the internal components from dust.
- Use only the recommended types of media cartridges, described earlier in this manual.
- Clean each of the DLT drives once a month, or whenever the **Use Cleaning Tape** LED is illuminated on a drive front panel (see the subsection titled *Cleaning the Drive Head* in the *Maintenance* section later in this chapter).

Power Up Checks

When you apply power to your library it will perform the following actions:

- Verifies drive configuration and status.
- Builds a valid cartridge inventory log.
- If **Init Scan Barcodes = Y**, and the barcode reader is enabled, the Scalar 218M builds a log of barcode labels for each location.
- Calibrates the positioning of the Media Picker.

When the library has completed the Power Up Checks it will automatically place itself in On-Line Mode.

Drive Power-on Self-Test

When you power up your Scalar 218M, the DLT drives each perform a Power-on Self-Test (POST) while the library is performing the Power Up Checks. The sequence of events for each drive is:

1. The LEDs on the right front panel of the drive will turn on sequentially from top to bottom. All LEDs will remain ON for a few seconds.
 2. The LEDs on the left front panel of the drive will turn ON at the same time for about three seconds and then turn OFF.
 3. The **Operate Handle**, **Write Protected**, and **Use Cleaning Tape** LEDs will turn OFF. The **Tape in Use** LED will blink while the tape drive initializes.
- ✓ If your external SCSI bus terminator has a Term Power LED it should also be illuminated.

Drive Status

After completion of the drive POST and initialization, each drive will be in one of the four states listed in the following table:

Drive State	Indicator Displays and Actions
1. No cartridge is present	A. The Tape in Use LED turns OFF. B. The Operate Handle LED turns ON. C. The handle is unlatched. D. The drive beeps momentarily.
2. A cartridge is present and the handle is closed.	The drive loads the cartridge. When the Tape in Use LED stops blinking and stays ON, the LED indicating the tape's actual density illuminates. For example, if the actual tape density is 2.6, then the LED turns ON next to the 2.6 label. When the Density Override LED blinks, you can select a density. The drive is ready for use.
3. A cartridge is present, but the handle is open.	The Tape in Use LED turns OFF. The Operate Handle LED flashes. The Scalar 218M will close the handle and the drive will load the cartridge. When the Tape in Use LED stops blinking and stays ON, the LED indicating the tape's actual density illuminates. For example, if the actual tape density is 2.6, then the LED turns ON next to the 2.6 label. When the Density Override LED blinks, you can select a density. The drive is ready for use.
4. The drive detects an error condition.	Then all right or left side LEDs blink repeatedly. You may try to unload the tape and reinitialize the drive by pressing the Unload key or turn power OFF and then ON again. The right or left side LEDs stop blinking and the drive tries to reinitialize. The LEDs turn ON steadily again and then turn OFF if the test succeeds.

The drive POST completes in about 13 seconds on each drive, and the drives will respond normally to all commands. However, it may take longer for the media to become ready.

Drive Operating Conditions

Use the following table to determine each drive's operating condition:

LED Label (Right Indicator Panel)	Color	State	Operating Condition
Write Protected	Orange	ON OFF	Tape is write-protected. Tape is write-enabled.
Tape in Use	Yellow	Blinking ON	Tape is moving. Tape is loaded; ready for use.
Use Cleaning Tape	Yellow	ON Remains on after unloading cleaning tape After cleaning, turns on again when reloading data cartridge	Drive head needs cleaning, or the tape is bad. Cleaning attempted, but tape expired, so cleaning not performed. Problem data cartridge. Try another cartridge.
Operate Handle	Green	ON OFF	OK to operate the Cartridge Insert/Release Handle. Do not operate the Cartridge Insert/Release Handle.
All Right Indicator Panel LEDs or, All Left Indicator Panel LEDs	•	ON Blinking	POST is starting. A POST error has occurred.

(continued on next page)

LED Label (Left Indicator Panel)	Color	State	Operating Condition
2.6 (DLT4000, DLT7000)	Yellow	ON Blinking	Tape is recorded in 2.6 format. Tape is recorded in another density. You selected this density for a write from BOT.
6.0 (DLT4000, DLT7000)	Yellow	ON Blinking	Tape is recorded in 6.0 format. Tape is recorded in another density. You selected this density for a write from BOT.
10.0 (DLT4000 only)	Yellow	ON (default) Blinking	Tape is recorded in 10.0 format. Tape is recorded in another density. You selected this density for a write from BOT.
10.0/15.0 (DLT7000, DLT8000)	Yellow	ON (default) Blinking	Tape is recorded in 10.0/15.0 format. Tape is recorded in another density. You selected this density for a write from BOT.
20.0 (DLT4000, DLT7000, DLT8000)	Yellow	ON (default) Blinking	Tape is recorded in 20.0 format. Tape is recorded in another density. You selected this density for a write from BOT.
35.0 (DLT7000, DLT8000)	Yellow	ON (default) Blinking	Tape is recorded in 35.0 format. Tape is recorded in another density. You selected this density for a write from BOT.
40.0 (DLT8000 only)	Yellow	ON (default) Blinking	Tape is recorded in 40.0 format. Tape is recorded in another density. You selected this density for a write from BOT.
Compress	Yellow	ON OFF	Compression mode enabled. (Compression available only in 10.0, 15.0, 20.0, 35.0, and 40.0 density.) Compression mode disabled.
Density Override	Yellow	ON OFF (default) Blinking	You selected a density from the front panel. Density will be selected by the host (automatic). You are in density selection mode.
All Right Indicator Panel LEDs, or, all Left Indicator Panel LEDs	•	ON Blinking	POST is starting. A POST error has occurred.

DLT Media

The data cartridge used in the DLT drive is housed in a four-inch plastic case and contains ½-inch metal particle tape.

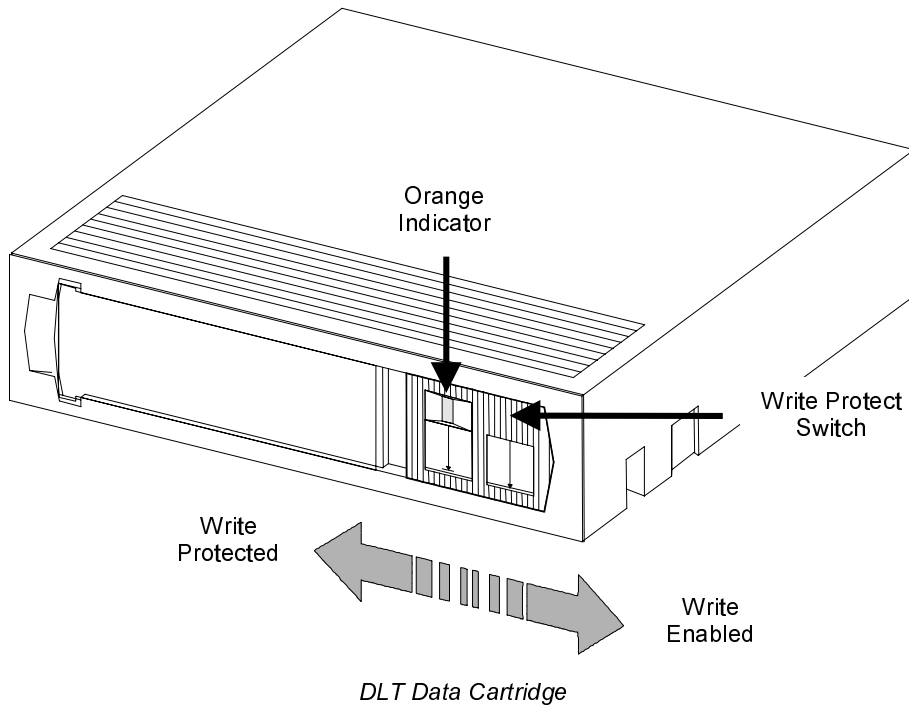

The write-protect switch prevents or allows recording over existing data. To prevent recording or deleting, place the write-protect switch to the write-protected position. When installing cartridges in the library, place the switch in the write-enabled position (unless you do not wish to record on a specific cartridge).

Notes

- A small orange rectangle is visible whenever the cartridge is write-protected (to the left).
- The orange rectangle will not be visible whenever the cartridge is write-enabled (to the right).
- Store data cartridges in a dry, cool environment.
- Never reset or power down your computer or Scalar 218M while a function is in process or a tape is moving.

Opening the Sliding Access Panel

Caution

Do not open the sliding access panel unless you need to replace data cartridges or perform a maintenance operation.

Desktop Unit

A sensor monitors the position of the access panel. Whenever the panel is opened all Media Picker activity stops and a SCSI UNIT ATTENTION is returned to the host. Drive activity is unaffected by the position of the panel. When the panel is again closed, the Scalar 218M resets, calibrates the Media Picker, and waits for a command from the host.

- Insert the key into the lock and turn it to the left to unlock.

Warning

Wait until any current application operations are completed.

- Turn the lock $\frac{1}{4}$ turn in either direction and hold while pushing the sliding access panel toward the rear of the Scalar 218M.

Rack-mount Unit

A sensor monitors the position of the Scalar in the rack. Whenever the Scalar is pulled out from the rack, all Media Picker activity stops and a SCSI UNIT ATTENTION is returned to the host. Drive activity is unaffected by the position of the front panel. When the Scalar is pushed back into the rack, the Scalar 218M resets, calibrates the Media Picker, and waits for a command from the host.

- Insert the key into the front panel slam lock and turn it to the left to unlock.

Warning

Wait until any current application operations are completed.

- Turn the slam lock knob $\frac{1}{4}$ turn in either direction and hold while pulling the Scalar out of the rack.

Using the Mailbox

On-Line Mode

Note

The application software can use the Mailbox as a cartridge input/output element only if it is first enabled. See *Off-Line Mode Menus, Configuration Menu, Enable Mailbox* in Chapter 4 of this manual for additional information.

In the On-Line mode, the application software controls the Mailbox. The application may add, or remove, a single cartridge, or a complete backup data set may be exchanged, one cartridge at a time. The cartridge must be placed into or removed from the Mailbox slot manually, whenever the application requests. When adding or removing a cartridge to/from the Mailbox slot, open the plastic window covering the slot to provide access.

Off-Line Mode

Moving a Cartridge to a Drive or Storage Slot

Use the Mailbox to place a data or cleaning cartridge directly into a drive or a storage slot.

- Open the plastic door over the Mailbox slot.
- Place the cartridge into the slot with the write-protect switch up, and facing toward you.
- Close the plastic door.
- Use the **Off-Line mode Diagnostics Menu, Pick from Mailbox** function to have the Picker move a cartridge from the Mailbox slot to a drive or storage slot. See *Appendix A: Diagnostics Menu*, later in this manual, for complete descriptions of the Pick and Place functions.

Moving a Cartridge to the Mailbox Slot

Move a data or cleaning cartridge from a drive or storage slot to the Mailbox as follows:

- Use the **Off-Line mode, Diagnostics Menu, Place in Mailbox** function to have the Picker move a cartridge from a drive or storage slot to the Mailbox slot. See *Appendix A: Diagnostics Menu*, later in this manual, for complete descriptions of the Pick and Place functions.
- Open the plastic door over the Mailbox slot.
- Remove the cartridge from the Mailbox manually.
- Close the plastic door.

Manually Loading/Unloading Cartridges to/from the Storage Slots (Bulk Loading)

Media can be exchanged on a “bulk” basis by opening the access panel and exchanging any or all cartridges in the slots. The application software will have to re-map the slots and re-scan the barcodes to update its cartridge inventory log when the loading/unloading is completed.

Note

You can manually move the Media Picker assembly right or left to provide access to the storage slots. Push the Picker at the bottom only, pushing at the top will cause the bearings to bind and the Picker will resist movement.

Normal Maintenance

Cleaning the Drive Head

Cleaning Tape

The tape heads should be cleaned once a month, or when the **Use Cleaning Tape** LED is illuminated on the drive front panel. Use a DLT cleaning tape to clean the drive heads.

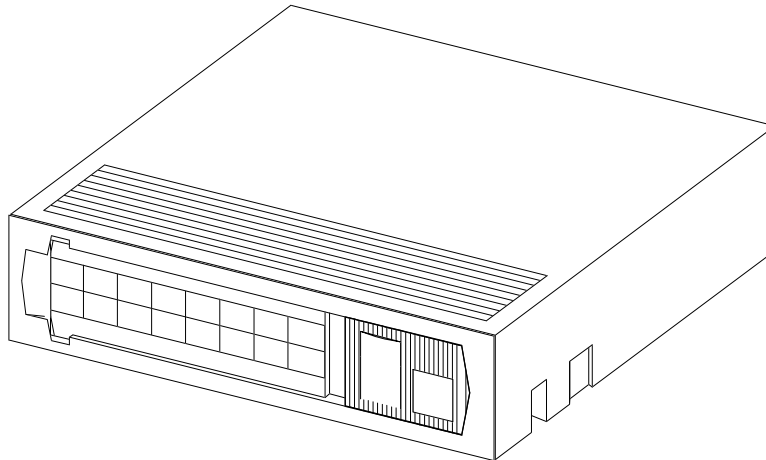

DLT Cleaning Tape

Cleaning the head should always be performed as the first step if the **Use Cleaning Tape** LED is illuminated on the drive.

Note

The cleaning cartridge is exhausted after it has performed 20 cleanings. The cleaning tape includes a label with 20 small boxes printed on it. Always place a check mark in a box each time the tape performs a cleaning. Replace the cleaning cartridge when it has performed 20 cleanings (all boxes will be checked).

The following table tells you when to use the cleaning tape:

If . . .	It means . . .	You should . . .
1. The Use Cleaning Tape LED is illuminated on the drive front panel	The drive head needs cleaning or the tape is bad	Use the cleaning tape. Load the cleaning tape using the procedure in section <i>Using the Mailbox</i> , subsection <i>Off-Line Mode</i> , subsection <i>Moving a Cartridge to a Drive or Storage Slot</i> earlier in this chapter. When cleaning is complete, the beeper will sound, alerting you to remove the cleaning tape. Use the procedure in section <i>Using the Mailbox</i> , subsection <i>Off-Line Mode</i> , subsection <i>Moving a Cartridge to the Mailbox</i> earlier in this chapter to remove the cleaning tape from the drive. Log the cleaning event onto the label.
2. A data cartridge causes the Use Cleaning Tape LED on the drive front panel to blink	The data cartridge may be damaged	Back up the data from this cartridge onto another cartridge, it may be damaged. A damaged cartridge may cause unnecessary use of the cleaning cartridge.
3. The Use Cleaning Tape LED re-illuminates after performing a cleaning and reloading the data cartridge	Cleaning was not accomplished because the cleaning tape has exhausted all cleaning cycles OR The data cartridge may be damaged	Replace the cleaning cartridge. Back up the data from this cartridge onto another cartridge. It may be damaged. A damaged cartridge may cause unnecessary use of the cleaning cartridge.

Note

Keeping a drive clean is the single most important requirement for achieving and maintaining superior performance.

Manual Head Cleaning Procedure

If desired, you can manually insert and remove the cleaning tape into/from the drive. To do this you must open the drive door using the **OFF-LINE Mode, Diagnostics Menu, Open Drive Door** function. You must also insert the cleaning cartridge into the drive by reaching down through the sliding access panel.

Note

To initiate the cleaning cycle manually you must be aware of the present state of the Scalar 218M and the drive that you wish to clean.

If a cartridge is present in the drive, you must first press the **UNLOAD** button on the drive front panel, then, when the **OPERATE HANDLE** LED is illuminated, open the drive door and remove the cartridge. You can then proceed with these instructions.

If the drive is empty, but the door is closed, make sure that the **OPERATE HANDLE** LED is illuminated before opening the door. You may then proceed with these instructions.

If the drive is empty, and the door is open, proceed with these instructions.

- Place the Scalar 218M in the **OFF-LINE Mode** by pressing the **MENU** key.
- Using the **Diagnostics Menu, Open Drive Door** function, open the door handle to the drive that you wish to clean.
- Open the sliding access panel of the Scalar 218M.

Note

You can manually move the Media Picker assembly right or left to provide access to the drives. Push on the Media Picker at the bottom only, pushing at the top will cause the bearings to bind and the Picker will resist moving.

- Insert the cleaning cartridge into the drive you wish to clean.
- Using the **Diagnostics Menu, Close Drive Door** function, close the drive door handle.

The cleaning cycle will be performed. When cleaning is completed, the **OPERATE HANDLE** LED will illuminate. Remove the cleaning cartridge and check a usage box on the label.

- To resume normal operation, place the Scalar 218M back in **ON-LINE Mode** by pressing the **MENU** key.

Cleaning the Enclosure

The outside of the enclosure can be cleaned with a damp towel. If you use a liquid all-purpose cleaner, apply it to the towel. Do not directly spray the enclosure.

Blank Page

Chapter 6

Troubleshooting and Diagnostics

This Chapter ...

- contains some general suggestions to aid you in solving problems – should you encounter them.
- includes information on error codes and the built-in diagnostics.

Installation Problems

Usually, problems encountered during the installation of your Scalar 218M are caused by improper SCSI bus configuration, application software configuration errors or by an OS that has not been correctly configured. If the application software that you are attempting to use is not communicating with your library after installation, check the following:

- ✓ **SCSI IDs:** Make sure that the IDs you selected for the library robotics and tape drives are not the same as the ID used by any other SCSI device on that bus, including the host SCSI adapter card.
- ✓ **SCSI Cabling:** Verify that all SCSI cables are securely connected at both ends and that all jackscrews are tightened. Also, check the length and integrity of your SCSI cabling. The total length of all cables connected to a SCSI bus must not exceed 25 meters (82 feet). Try replacing suspected cables with known good cables.

Note

The length of the Scalar 218M internal SCSI cables is 1 foot. This length must be included in any calculations of cable length.

- ✓ **Termination:** Check that all SCSI buses are properly terminated.
- ✓ **Compatibility:** Ensure that your library and its tape drives are compatible with the SCSI adapter card and application software you plan to use.

Note

For a list of compatible SCSI adapters and application software, call ADIC's Technical Assistance Center (ATAC) at (800) 827-3822. In Europe, call ATAC at 00.800.9999.3822.

- ✓ **SCSI Adapter Card Installation:** Verify that you have installed your SCSI adapter card correctly. Refer to the documentation that came with your card for installation and troubleshooting instructions. Pay particular attention to any steps describing the settings of various jumpers and/or switches on the card. Check that the card is seated fully in your computer's I/O connector.
- ✓ **Application Software Installation:** Refer to the documentation included with your software for instructions on how to verify installation.

Library and Drive Operational Problems

Most problems with the operation of your Scalar 218M and/or DLT drives happen when the drives are not cleaned regularly or when you use incorrect data cartridges. If you have been successfully operating the application software and library in the past, but are now experiencing problems reading and writing data, check the following:

- ✓ If you are writing data, make sure that the cartridge is write enabled (move the write-protect switch to the enabled position).
- ✓ Check the data cartridge you are using to verify compatibility with your drive model.

-
- ✓ If the cartridge has been in use for a long time or if it has been used frequently, try using a new cartridge.
 - ✓ Clean the drive head.

Library Error Codes

If, during operation of your Scalar 218M an error occurs, the library will halt the current operation and an error code will be displayed on the operator's display. The error code is displayed at the beginning of the fourth line and will consist of two hexadecimal characters. The first three lines will not be changed.

In all cases, after removing the cause of the problem push **MENU** to return the Scalar 218M to the On-Line Mode.

If you cannot find a cause for the error, try to return the Scalar 218M to the On-Line Mode by pressing **ALT** and/or **ENTER**. If that does not work, or if the error code reappears, call ADIC Customer Assistance and be prepared to tell them what the error code is – and what the conditions are (see *When You Call ADIC's Technical Assistance Center* later in this chapter).

See *Appendix B: Error Codes* in this manual for a detailed description of the more common error codes. Contact ATAC if your error code is not listed.

Environmental Considerations

For best performance of your Scalar 218M, and to minimize the chance of condensation, please observe the following guidelines:

- If you expose cartridges to temperatures outside the operating limits; 5-40°C (40-104°F) – stabilize them by leaving the cartridges in the operating temperature for a minimum of two hours before you use them.
- Avoid temperature problems by ensuring that the Scalar 218M rear panel is not obstructed so that the drives have adequate ventilation.

Note

The Scalar 218M displays the current internal temperature (in degrees centigrade) of the library on the Operator Panel LCD. Whenever the internal temperature meets or exceeds 40°C, an alarm will sound and a message appears on the LCD stating that the safe operating temperature has been exceeded.

Once the temperature falls below 40°C, the alarm quits and the message is removed from the LCD.

- Position the Scalar 218M where the temperature is relatively stable (i.e., away from open windows, fan heaters, and doors).
- Avoid leaving cartridges in severe temperature conditions, for example, in a car standing in bright sunlight.
- Avoid transferring data (reading from and writing to cartridges) when the temperature is changing by more than 10°C (15°F) per hour.

When You Call ADIC's Technical Assistance Center

Before calling ADIC's Technical Assistance Center (ATAC), follow these steps – which will help you take full advantage of your call:

- Review all documentation carefully. (Experience has demonstrated that most questions are answered in your documentation.)
- Be prepared to explain whether the software or hardware has worked properly at anytime in the past. Have you changed anything recently?
- Pinpoint the exact location of your problem, if possible. Note the steps that led to the problem. Are you able to duplicate the same problem or is it a one-time occurrence?
- Note any error messages displayed on your PC screen or file server. Write down the exact error message.
- If at all possible, call while at your computer, with ADIC's system installed and turned on.
- If running on a network, have all relevant information available (i.e. type, version number, network hardware, etc.).
- Be prepared to provide:
 - Your name and your Company's name
 - Model number
 - Serial number of unit (located on the rear face by the AC input module)
 - Software version numbers
 - device driver
 - archive/restore
 - Hardware configuration, including firmware version, date and number
 - Type of server, OS version, clock speed, RAM, network type, network version, and any special boards installed
 - A brief description of the problem
 - Where you purchased the ADIC system

Having this information available when you call for customer assistance will enable ADIC to resolve your problem in the most efficient manner possible.

Note

Call ADIC's Technical Assistance Center at (800) 827-3822. In Europe, call ATAC at 00.800.9999.3822.

Appendix

A

Diagnostics Menu

This Appendix ...

- describes the built-in diagnostic functions available via the Off-Line mode, Diagnostics Menu

One of the most valuable features of the Scalar 218M is the extensive built-in diagnostics. In this Appendix we discuss each of the Diagnostic functions available through the front panel keypad.



The following functions are available under the Diagnostics Menu:

- Open Drive Door
- Close Drive Door
- Firmware Revision
- Map Slots & Drives
- Pos Picker at Slot
- Pos Picker at Mbox
- Pos Picker at Drv
- Pick From Slot
- Pick From Mbox
- Pick From Drv
- Place In Slot
- Place In Mbox
- Place In Drv
- Event Counters
- Operation Log
- Calibrate Position
- Display Sensors
- Run Demo

Warning

We highly recommend that these diagnostic functions be used only by a qualified service technician (or on the instruction of a qualified technician). Some of these functions assume that the unit has been set up correctly and thus many of the normal built-in safety checks are turned off. Misusing these diagnostic functions without the normal safety checks could result in improper operation (or even damage to media or the Scalar 218M).

Open Drive Door

```
OPEN DRIVE DOOR
Drv dd
```

The **Open Drive Door** function will cause the Scalar 218M to open the door of the selected drive. If the door is already open the drive door motor will run for a short time. If a tape is present in the drive, and it has not been logically unloaded, an error will occur and an error message will be displayed on the Operators Panel.

- Use **LEFT** or **RIGHT** to select the desired field. Select the drive row and drive using **UP** or **DOWN**. Press **ENTER** to activate.

dd = Drive number (01 - 02)

Close Drive Door

```
CLOSE DRIVE DOOR
Drv dd
```

The **Close Drive Door** function will cause the Scalar 218M to close the door of the selected drive. If the door is already closed the drive door motor will run for a short time.

- Use **LEFT** or **RIGHT** to select the desired field. Select the drive row and drive using **UP** or **DOWN**. Press **ENTER** to activate.

dd = Drive number (01 - 02)

Firmware Revision

Provides a record of the internal revision date and number, and internal checksum value of the firmware for the Main CPU, Motion CPU, Picker CPU, and Servo Controller. This information is vital for troubleshooting problems.

```
FIRMWARE REVISION
Main CPU Flash
```

- Press **ENTER** to list the F/W revision information for the Main CPU.

```
MAIN CPU FLASH F/W
Revision: UUvv
Date: yyyy-mm-dd
Checksum: cccch
```

- VV = Major version number (00-99)
- vv = Minor version number (00-99)
- yyyy = Build date year (00-99)
- mm = Build date month (01-12)
- dd = Build date day (01-31)
- cccc = Internal checksum (0000-FFFF) [hexadecimal]

- Press **ESC** to return to the **FIRMWARE REVISION** main screen.
- Press the **DOWN** arrow key to bring up the **Motion CPU** selection.

```
FIRMWARE REVISION
Motion CPU Flash
```

- Press **ENTER** to select the **Motion CPU**.

```
MOTION CPU FLASH F/W
Revision: UUvv
Date: yyyy-mm-dd
Checksum: cccch
```

- Press **ESC** to return to the **FIRMWARE REVISION** main screen.
- Press the **DOWN** arrow key to bring up the **Picker CPU** selection.

```
FIRMWARE REVISION
Picker CPU
```

- Press **ENTER** to select the **Picker CPU**.

```
PICKER CPU F/W
Revision: UUvv
Date: mm/dd/yy
```

- Press **ESC** to return to the **FIRMWARE REVISION** main screen.
- Press the **DOWN** arrow key to bring up the **Servo Controller CPU** selection.

```
FIRMWARE REVISION
Servo Controller
```

- Press **ENTER** to select the **Servo Controller**.

```
SERVO CONTROLLER F/W
Revision: UUvv
Date: mm/dd/yy
```

- Press **ESC** twice to return to the **Diagnostics Menu** main screen.

Map Slots & Drives

```
MAP SLOTS & DRIVES
Scan Barcodes: Y
```

The **Map Slots & Drives** function will cause the Scalar 218M to update its cartridge inventory log. Selecting “N” in the **Scan Barcodes** field will prevent the library from updating its barcodes inventory log. If the **Configuration Menu, Barcode Scanner** parameter is set to “N”, the setting of the **Scan Barcodes** field is ignored.

- Use **LEFT** or **RIGHT** to select the **Scan Barcodes** field. Use **UP** or **DOWN** to select **Y** or **N**. Press **ENTER** to activate.

This function is usually used for diagnostics only by a trained technician.

Pos Picker at Slot

```
POS PICKER AT SLOT
Slot ss
```

The **Pos Picker at Slot** function is used to position the Media Picker at a particular cartridge storage slot in preparation to either pick, or place a cartridge from/into the slot. The maximum slot number is dependent upon the setting of the **Configuration Menu, Adjust Slot Count** parameter.

- Use **LEFT** or **RIGHT** to select the desired field. Select the row or slot using **UP** or **DOWN**. Press **ENTER** to activate.

ss = Slot number (01 – 17, 01 – 16 if **ADJUST SLOT COUNT** set to 16)

Pos Picker at Mbox

```
POS PICKER AT MBOX
```

The **Pos Picker at Mbox** function is used to position the Media Picker at the Mailbox slot in preparation to either pick a cartridge from the Mailbox, or place a cartridge into the Mailbox.

- Press **ENTER** to activate.

Note

The application software can use the Mailbox as a cartridge input/output element only if it is first enabled. See *Off-Line Mode Menus, Configuration Menu, Enable Mailbox* in Chapter 4 of this manual for additional information.

Pos Picker at Drv

```
POS PICKER AT DRU
Drv dd
```

The **Pos Picker at Drv** function is used to position the Media Picker at a drive in preparation to either pick a cartridge from the drive, or place a cartridge into the drive.

- Use **LEFT** or **RIGHT** to select the desired field. Select the row or slot using **UP** or **DOWN**. Press **ENTER** to activate.

dd = Drive number (01 - 02)

Pick From Slot



PICK FROM SLOT
Slot ss

The **Pick From Slot** function will cause the Media Picker to pick the cartridge from a particular cartridge storage slot in preparation to place it either in another storage slot, into a Mailbox slot, or in a drive. The maximum slot number is dependent upon the setting of the **Configuration Menu, Adjust Slot Count** parameter.

- Use **LEFT** or **RIGHT** to select the desired field. Select the row or slot using **UP** or **DOWN**. Press **ENTER** to activate.

ss = Slot number (01 – 17, 01 - 16 if ADJUST SLOT COUNT set to 16)

Pick From Mailbox



PICK FROM MAILBOX

The **Pick From Mailbox** function will cause the Media Picker to pick the cartridge from the Mailbox in preparation to placing the cartridge either in a storage slot or in a drive.

- Press **ENTER** to activate.

Note

The application software can use the Mailbox as a cartridge input/output element only if it is first enabled. See *Off-Line Mode Menus, Configuration Menu, Enable Mailbox* in Chapter 4 of this manual for additional information.

Pick From Drive



PICK FROM DRIVE
Drv dd

The **Pick From Drive** function will cause the drive to unload and eject the cartridge and the Media Picker to pick the cartridge in preparation to placing the cartridge either in a storage slot or in a Mailbox slot.

-
- Use **LEFT** or **RIGHT** to select the desired field. Select the row or slot using **UP** or **DOWN**. Press **ENTER** to activate.

dd = Drive number (01 - 02)

Place In Slot



PLACE IN SLOT
Slot ss

The **Place In Slot** function will cause the Media Picker to place the cartridge into a storage slot. The maximum slot number is dependent upon the setting of the **Configuration Menu, Adjust Slot Count** parameter.

- Use **LEFT** or **RIGHT** to select the desired field. Select the row and slot using **UP** or **DOWN**. Press **ENTER** to activate.

ss = Slot number (01 – 17, 01 – 16 if ADJUST SLOT COUNT set to 16)

Place In Mailbox



PLACE IN MAILBOX

The **Place In Mailbox** function will cause the Media Picker to place a cartridge into the Mailbox.

- Press **ENTER** to activate.

Note

The application software can use the Mailbox as a cartridge input/output element only if it is first enabled. See *Off-Line Mode Menus, Configuration Menu, Enable Mailbox* in Chapter 4 of this manual for additional information.

Place In Drive



PLACE IN DRIVE
Drv dd

The **Place In Drive** function will cause the drive door to open and the Media Picker to place the cartridge into the drive.

-
- ❑ Use **LEFT** or **RIGHT** to select the desired field. Select the drive row and drive using **UP** or **DOWN**. Press **ENTER** to activate.

dd = Drive number (01 - 02)

Event Counters

```
EVENT COUNTERS          ↵
nnnnnnnnnnnnnnnnnnnn
nnnnnnnn#
cccccc
```

Provides a listing of the various Scalar 218M operations and how many times they have occurred. Below is a listing of Event Counter listings with an indication of what each refers to:

nnnnnnnn = Counter name
cccccc = Counter value (0 - 65535)

Operation Log

```
OPERATION LOG          ↵
Operation # NNN
nnnnnnnnnnnnnnnnnnnn
```

Provides a chronological logging (beginning with the latest) of up to 255 operations. These operations can be SCSI commands, operator requested operations, errors, and status operations. This information can be vital for trouble shooting problems. The following is a partial listing of some of the loggable operations. You may encounter other operations not included here.

NNN = Logged operation number (1-255). When log is full, new operations are logged in as operation 255, scrolling the old operation 1 off the log.

nnnnnnnn = Operation name

- Power on or user reset
- Unit on-line due to user request
- Unit off-line due to user request
- Cmd: 03 00 00 00 20 00 (cmd is from SCSI host adapter)
- SCSI selection by SCSI ID N (N = SCSI ID of host adapter)
- SCSI reselection of SCSI ID N
- SCSI disconnect from SCSI ID N
- SCSI status = 00h (status to SCSI host adapter)
- Door opened
- Door closed
- ERROR: Can't unload, media in drive(s)
- ERROR: Source location empty
- Retrying operation

Calibrate Position



The **Calibrate Position** function will cause the Scalar 218M to move the Media Picker to the home position and update its home position constant.

- Press **ENTER** to activate.

This function is usually used for diagnostics only by a trained technician.

Display Sensors



The **Display Sensors** function causes the Scalar 218M to display the present state of its sensors.

- Press **ENTER** to activate. The display will appear similar to the following:



The HM sensor is the sensor that the Media Picker homes to when calibrating. The MBDR sensor indicates the state of the Mailbox door, 0 = closed; 1 = open. The six SLOTS sensors indicate the states of cartridge storage slots 12-17. On the desktop Scalar, the DOOR sensor indicates the state of the sliding access panel, 0 = closed; 1 = open. On the rack-mounted Scalar, the DOOR sensor indicates the position of the Scalar within the rack, 0 = Scalar pushed into rack; 1 = Scalar pulled out from rack. The 12 sensors at the beginning of the third line indicate the states of the Mailbox and cartridge storage slots 1-11, 0 = slot empty; 1 = slot full. The 11 sensors at the beginning of line 4 indicate the state of the cartridges installed in slots 1-11, 0 = cartridge installed correctly; 1 = cartridge installed incorrectly (i.e., may be upside-down). The DRV 1 and DRV2 sensors indicate presence of a drive, 1 = drive present. If DRV2 displays X, the drive is not present.

This function is usually used for diagnostics only by a trained technician.

Run Demo



RUN DEMO

The **Run Demo** function causes the Scalar 218M to execute a demo program included in its firmware. The demo assumes that cartridge storage slots 1 through 11 are occupied and the Mailbox has a cartridge loaded, that slots 12 through 17 are empty, and that neither drive has a cartridge loaded. The program picks cartridges from the occupied slots and places them in empty slots and also the drives. The Demo continues to run until the **ESC** key is pressed. Pressing **ESC** a second time causes the Scalar 218M to exit the program.

- Press **ENTER** to activate.

Blank Page

Appendix B

Error Codes

This Appendix ...

- contains descriptions of the error codes that can be displayed on the Scalar 218M Library Operator's Panel.

Error Code Listing

The Scalar 218M will display a 2-digit hex code on the bottom line of the LCD whenever certain types of errors occur. The characters will be placed in the first 2 columns on the line. A description of each of the error codes is provided below:

Code	Name	Description
06	Source location is empty	The source location was empty when the Picker attempted to pick from it during a pick and place operation.
07	Destination location is full	The destination was full when the Picker attempted to place a cartridge in it during a pick and place operation.
0C	Door is open	This code is displayed whenever the sliding access panel is open when the Picker is starting to execute a motion command.
0D	Door	Means that the door was open, but is now closed. This code will only appear on the serial port, it should never appear on the display. It should never be output on the serial port unless a 0C (see above) precedes it.
27	Invalid Picker response	This error code appears whenever the Picker CPU does not return the <i>proper</i> response to a Master CPU command.
28	Drive ready timeout	This error appears whenever the 'OK to Operate Handle' bit is not set within a specific time-out period.
29	No drive	During Power-up the drive did not output a serial data stream. This normally occurs during the Scalar 218M boot process.
2A	No response from Picker	This error code appears whenever the Picker CPU does not return <i>any</i> response to a Master CPU command.
2B	Picker command timeout	This error appears whenever the Picker CPU does not return results from executing a command within a time-out limit.
2C	Barcode failure	All barcode errors return this code.
32	X-axis position error	An X-axis position error will occur whenever the X-axis position reported by the servo CPU does not match the position reported by the X-axis optical tachometer plus or minus a margin value.
FE or 7E	Framing error	An inter-processor communications error on the serial communications line.
FD or 7D	Jaw centering error	Picker jaw centering error. May be caused by something blocking the jaw.
FC or 7C	Not empty error	The Picker attempted a pick operation but already had a cartridge in it.

FB or 7B	Lost cartridge error	The Picker should already have a cartridge, but no cartridge is present.
FA or 7A	No cartridge error	The Picker attempted a place operation, but no cartridge was present in Picker.
F9 or 79	Can't place error	The Picker attempted a place operation, but the Picker carriage could not get to the correct location.
F8 or 78	Unknown Picker position error	The Picker carriage is not where it should be and the Picker cannot return it to a known location.
F6 or 76	Picker centering error	The Picker attempted to center the carriage, the jaw, and the gripper, but one or more of them would not center.
F5 or 75	Picker timeout error	The Picker attempted a pick operation, but could not complete the operation and timed-out.
F4 or 74	Cartridge jam error	This is a roller time-out error that occurs when the picker is rolling a cartridge out.
F3 or 73	Cartridge timeout error	This is a roller time-out error that occurs when the picker is rolling a cartridge in.
F2 or 72	Jaw frozen error	The jaws do not move at all.
F1 or 71	Jaw timeout error	The jaws are able to move, but cannot complete a function.
F0 or 70	Jaw positioning error	The jaws are not in the proper position.
EF or 6F	Jaw limit error	The jaws are moving and expecting to see sensor feedback to know when to stop movement, but the servo processor says that the jaws have reached a limit first.
EE or 6E	Mailbox empty error	Attempted Mailbox pick operation, but no cartridge is present.
ED or 6D	Barcode timeout error	The barcode reader did not return the barcode data in time.
EC or 6C	System fault error	This indicates that a Picker controller board error occurred.
EB or 6B	Picker position error	The Picker carriage is in the wrong position.
EA or 6A	Barcode termination error	This is an acknowledgment of a barcode read abort command.
E9 or 69	Barcode receiver error	Any serial data stream formatting error causes this.

Blank Page

Appendix

C

Scalar 218M Rack-Mount Installation

This Appendix ...

- contains complete instructions on how to install your Scalar 218M into your rack.

Preparing the Rack

Tools Required

- # 1 phillips screwdriver
- 11/32" nutdriver

Mounting the Rails

- Using a tape measure or other device, measure and record the inside distance between the rack uprights. See illustration below for an example:

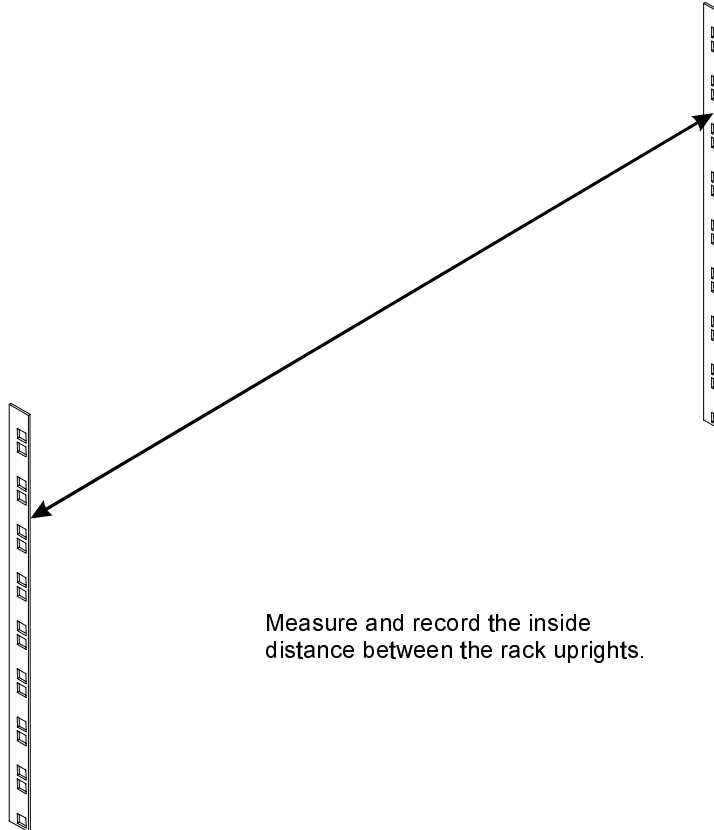

Measure and record the inside distance between the rack uprights.

-
- ❑ Match the holes in the mounting flange of an outer rail to the holes in your rack upright. You must use holes that have the same spacing when mounting the Scalar in your rack.

Align the holes in the rack upright with the outer rail mounting flange.

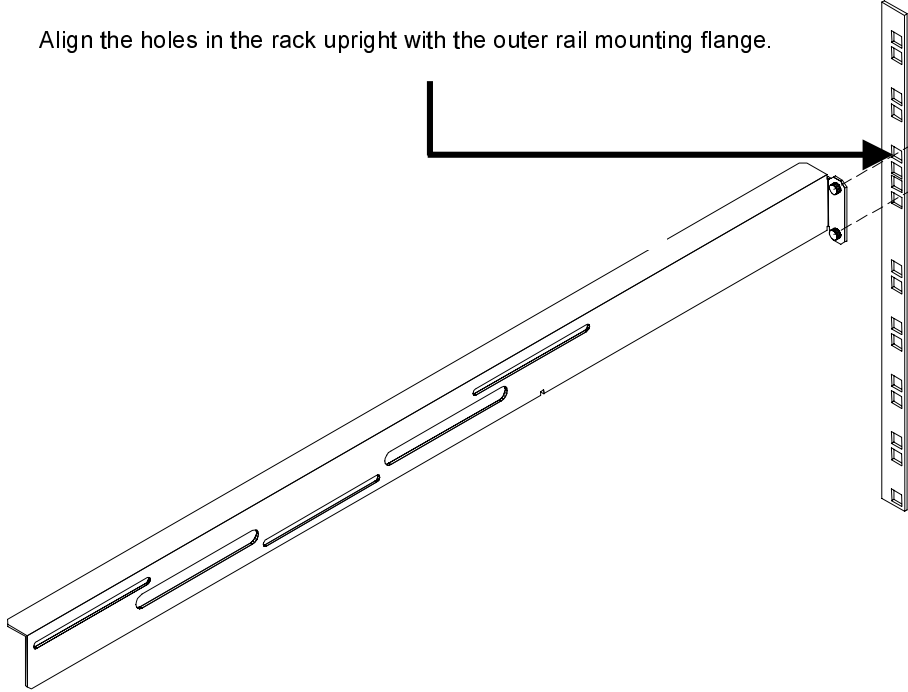

-
- Mount the outer rails to the Scalar 218M by placing each rail over the three studs on each side of the unit. Loosely secure the outer rails to the studs using three nylock nuts. **Do not** tighten the nuts completely. The following illustration shows the location of the rail-mounting studs.

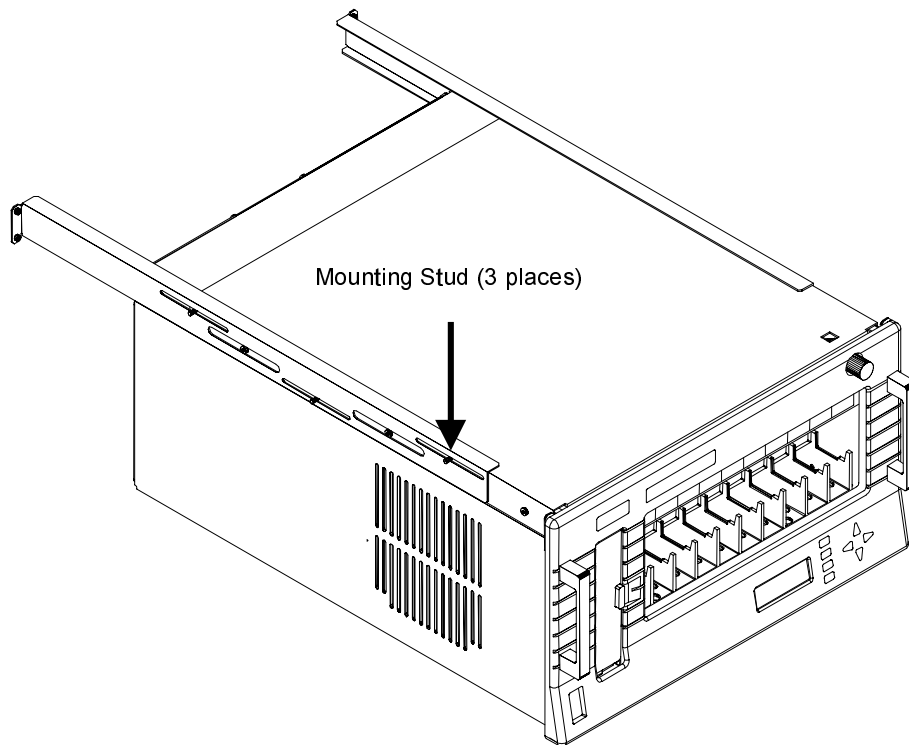

- Adjust the position of the outer rails until the distance between the outside surface of the mounting flanges is equal to the measurement you recorded when you measured the distance between the rack uprights.
- Once the rail length is adjusted, tighten the nylock nuts securely.

The next step in the installation process is to remove the Scalar from the rails so that you may install them in your rack.

For maximum protection, your rack-mount Scalar 218M was shipped from the factory with the front panel locked in the closed (operating) position. The front panel lock serves two purposes; when engaged with the key, the Scalar 218M cannot be pulled forward on its slides, preventing unauthorized access to the data cartridge storage bay; when disengaged, the lock works as a latch, holding the Scalar 218M in the operating position.

- Using the key, unlock the front panel.

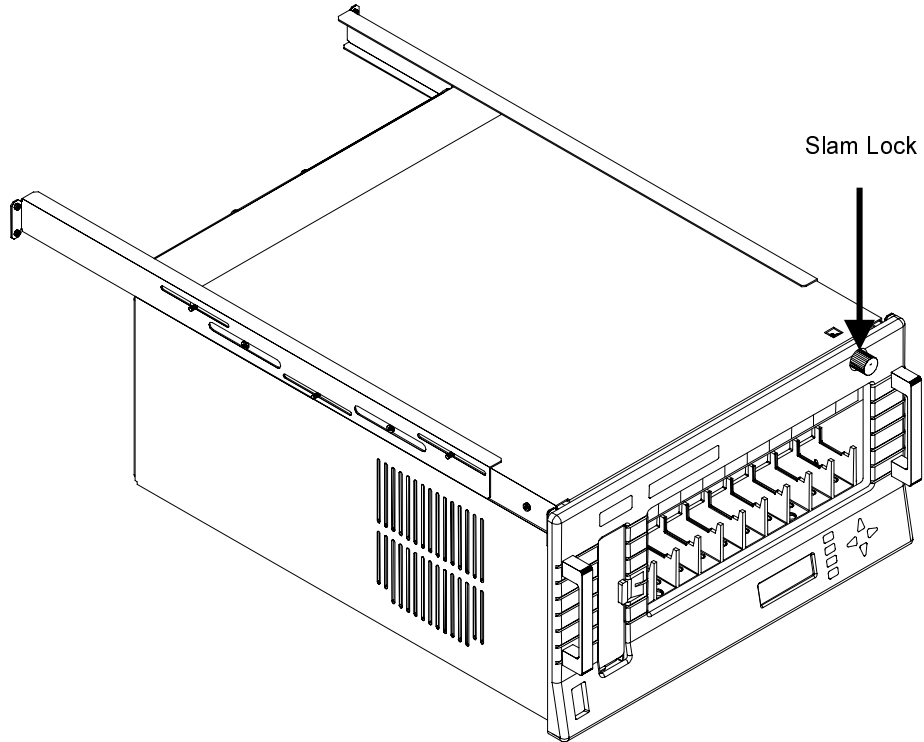

- Turn the lock $\frac{1}{4}$ turn in either direction while pushing the plate/rail subassembly rearward.
- Slide the plate/rail subassembly all the way rearward until the slide stops engage.
- While depressing both slide stop releases, slide the plate/rail subassembly off the inner slides.

If the holes in the uprights of your rack are square, you must install the plate/rail subassembly using the large collared spacers included in the hardware. If the holes in the uprights of your rack are round, you must install the plate/rail subassembly using the small collared spacers included in the hardware. This will position the rails correctly.

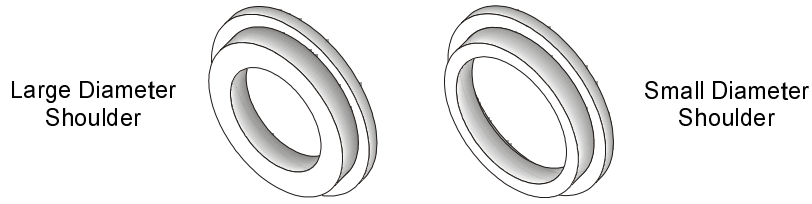

- While a helper holds the plate/rail subassembly in position, secure each rail mounting flange to the rack upright with a spacer and a 10-32 x 1/2" phillips head screw. The spacers are positioned on the outside of the rails. Be sure that the small end of the spacer is inserted completely into the hole in the upright. Tighten the screws.

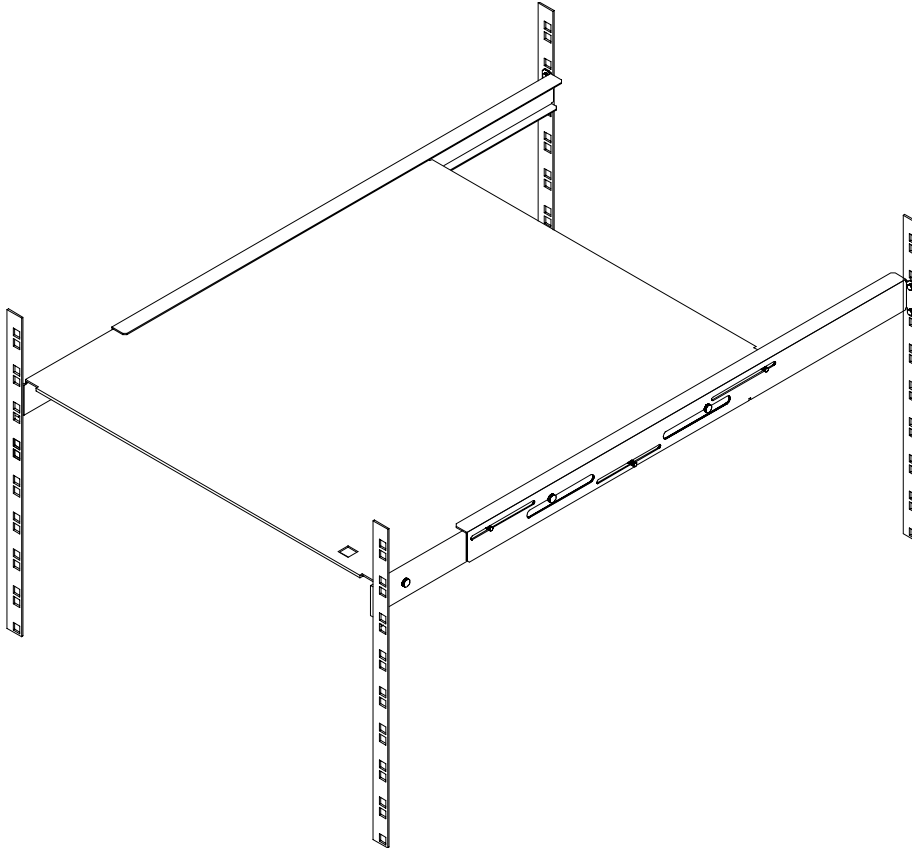

Installing the Scalar 218M into the Rack

Warning

The Scalar 218M weighs 70 pounds when it is equipped with two drives. **Do Not** attempt to lift the Scalar by yourself. To avoid possible injury, and damage to the equipment, always use two people to lift the Scalar.

- With your assistant, lift the Scalar 218M up and slide the slides into the rails. The slides will continue past the slide stops. It is not necessary to depress them when pushing the Scalar into the rails.

Notes

- It may be necessary to slightly adjust the position of the plate/rail subassembly on the rack uprights after you have installed the Scalar 218M.
- To determine if you need to adjust the position, unlatch the front panel lock, slide the Scalar 218M in and out on the rails, and listen for anything scraping.
- If you hear scraping sounds, note which side they seem to be coming from, then slightly loosen both screws on the front or rear rail mounting flange on that side.
- Again, slide the Scalar 218M in and out, while continuing to listen for scraping. If the scraping stops, tighten the screws and recheck.
- If necessary, try adjusting the mounting flange on the opposite end of the rail.

Installing the Cable Channel

The next step in the installation process is to install the cable channel bracket, cable channel, and channel stop at the rear of the rack. The cable channel will keep the SCSI and power cable(s) orderly and prevent them from hampering the movement of the Scalar 218M whenever it is slid forward on the rails. The cable channel is secured to the channel bracket with a quick-release pin.

- At the rear of your rack, select the pair of holes in the rack upright where you wish to install the cable channel. ADIC recommends that you use a pair of holes that vertically is at about the same height as the AC power connector on the rear panel of the Scalar 218M.
- Install the cable channel bracket using two 10-32 x ½" phillips head screws and two collared spacers.
- Install the channel stop using two 10-32 x ½" phillips head screws and two collared spacers.
- Secure the power cord and SCSI cable to the cable channel using the attached cable ties. Be sure to leave enough slack in the cables to allow the Scalar 218M to be pulled away from the rack as far as the slide stops permit. The illustration on the following page shows how the channel should be installed in your rack.

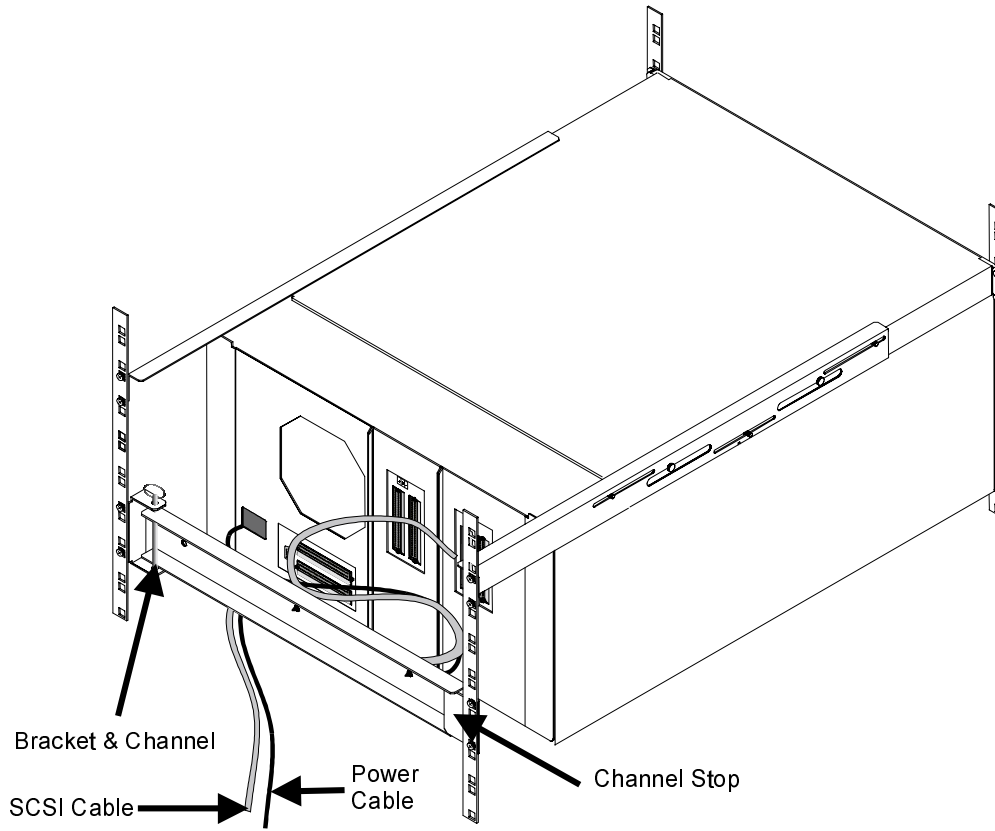

This completes the rack-mount Scalar 218M installation process. Return to the *Preparing the Library* section in *Chapter 2: Getting Started*.

Appendix

D

Glossary

This Appendix ...

- contains terms and definitions of common expressions used with the Scalar 218M and the DLT drive.

cartridge	A storage medium item. A cartridge is sometimes called a tape or cassette and is capable of storing vast amounts of magnetically written data. The DLT drives in the Scalar 218M uses DLTTape III, IIIXT, and/or IV cartridges.
cleaning cartridge	Media used to clean the drive heads and tape path.
DLT	DLT™ is the industry-standard data interchange recording format that supports the use of DLT for computer applications.
DLT media cartridge	Media used with the DLT tape drive in the Scalar 218M unit. It is a 4-inch cartridge containing either 1100 or 1800 feet of ½-inch metal-particle tape. These cartridges require no formatting or other media conditioning before use.
DLT drive	Tape drive used in the Scalar 218M.
FCC	Federal Communications Commission
HSM	Hierarchical Storage Management – a system where different types of storage medium are used based on cost and time efficiency. For example, for fastest access, data is usually stored on a local drive. If you have a very large file that is needed occasionally, you may store it on a tape in the Scalar 218M, or on an optical drive. In an HSM system, the data source should be transparent to the user.
LCD	Liquid Crystal Display, a commonly used alphanumeric display that responds to specified input voltages and signals
LED	Light Emitting Diode, a commonly used semiconductor device that glows when supplied with a specified voltage.
load	The process where the Scalar 218M uses the Media Picker to pick a cartridge from either a cartridge storage slot location, or from the Mailbox slot and load it into a drive.
Mailbox	The Mailbox allows insertion/removal of one cartridge from the library without the interruption of normal operation.
POST	Power-On Self-Test is a built-in self-test for the DLT drive. POST automatically occurs each time the Scalar 218M powers up.
RMA	Return Merchandise Authorization.
RMA number	An identifying number given to a customer who needs to return equipment for repair, whether under warranty or not.
SCSI	Small Computer System Interface. An industry standard for connecting peripheral devices and their controllers to a microprocessor. The SCSI defines both hardware and software standards for communication between a host computer and a peripheral.
SCSI ID	The octal representation of the unique address (0 to 7) assigned to a SCSI device.

SCSI bus	Signal path or line shared by the devices on the same SCSI channel. Information is often sent to all devices throughout the same bus; only the device to which it is addressed will accept it.
slot	A slot is a position within the cartridge storage area where the media is placed. Each slot has a reference position, i.e. position 1 through position 17.
terminator	A physical block which tells the SCSI bus that this is the end of the line. A terminator is required at both ends of a SCSI bus. A bus may be terminated internally (on a device inside the host system) or externally on a peripheral device.
unload	The process where the Scalar 218M causes a drive to eject a cartridge, then uses the Media Picker to move the cartridge to a storage slot location.

Blank Page

Appendix

E

Specifications

This Appendix ...

- contains specification information on the Scalar 218M Library and the DLT drive.

Drive:

Type:	Quantum [®] model DLT4000 Quantum [®] model DLT7000 Quantum [®] model DLT8000
Data Capacity: (avg. 2:1 compression)	Up to 40 GB per 1800 ft cartridge (DLT4000) Up to 70 GB per 1800 ft cartridge (DLT7000) Up to 80 GB per 1800 ft cartridge (DLT8000) Up to 1.44 TB – Scalar 218M (with 18 cartridge slots full)
Data Throughput: (avg. 2:1 compression)	3.0 MB/sec. sustained (360 MB/min., 2 DLT4000 drives) 10.0 MB/sec. sustained (1.20 GB/min., 2 DLT7000 drives) 12.0 MB/sec. sustained (1.44 GB/min., 2 DLT8000 drives)

Library:

Media type:	DLT ½-inch, metal-particle cartridges
Cartridge Change:	≤ 10 seconds
Indicators/Controls:	8 key (4 menu keys, 4 direction keys) keypad with LCD display, to monitor and control system status, diagnostics and configuration
Interface:	HVD SCSI, Fast Wide SCSI, Serial

Reliability:

Maintenance:	Use cleaning cartridge whenever the Use Cleaning Tape LED is illuminated on a drive front panel.
MSBF:	Greater than 1,000,000 cartridge changes (net, drive and media) with scheduled maintenance.
MTBF:	More than 80,000 power-on hours
MTTR:	Within 30 minutes

Physical:

Dimensions:	19.0"/48.3cm (w) x 24.5"/62.2cm (d) x 10.5"/26.7cm (h)
Weight:	70 lb/31.75 Kg (w/2 drives)
Shipping Weight:	90 lb/40.82 Kg (w/2 drives)

Power Consumption:

Less than 130 Watts

Environment:

Electrical:	100-240 VAC, 47-63 Hz, 2.25 - 1.25 A max
Temperature:	10° C to 40° C (Operating) -40° C to 70° C (Storage/Shipping)
Humidity:	20% to 80% RH, non-condensing (Operating) 90% maximum (Storage/Shipping)
Vibration:	0.3 g peak, 5-500-5 Hz, swept sine; 0.0002 g (sq.)/Hz, 5-350 Hz (Operating) 0.01 g continuous, 0.50 g peak (Storage/Shipping)
Shock:	3 g for 15 ms, ½ sine (Operating) 20 g peak 3 ms ½ sine (Storage/Shipping)

Index

1
10.0 GB format, 4, 35
15.0 GB format, 4, 35

2
2.6 GB format, 4, 35
20.0 GB format, 4, 35

3
35.0 GB format, 4, 35

4
40.0 GB format, 4, 35

6
6.0 GB format, 4, 35

A
AC Input Connector, 22
Adjust Slot Count parameter, 23, 24, 28, 29, 54, 55, 56
ALT key, 20, 25, 45
application software, 3, 4, 6, 18, 25, 32, 44, 45
archiving, 2

B
backup operations, 32
backup software, 6, 11, 12, 18
barcode label, 3, 9, 10
Barcode Scanner, 3
Barcode Scanner parameter, 23, 24, 27, 53
barcodes inventory log, 53
Built-in Diagnostics, 4
Buzzer Configuration parameter, 23, 24

C
cable channel, 6, 71
cable channel bracket, 71
Calibrate Position function, 23, 50, 58
Cartridge Data Capacity, 78
cartridge inventory, 32
cartridge inventory log, 53
Cartridge Pre-Check, 3
channel stop, 6, 71

clean the drive, 4
cleaning cartridge, 3, 7, 11, 39, 40, 74, 78
Cleaning the Drive Head, 39
Cleaning the Enclosure, 41
Close Drive Door function, 23, 29, 41, 50, 51
Compression mode, 35
Configuration Menu, 23, 24, 27, 53, 54, 55, 56
Copyright Notice, *ii*
Copyright Notice, Europe, *iii*

D
daisy chain cables, 14
data logging of drive errors, 4
data logging of operational errors, 4
data reliability, 2
data storage software, 12
Data Throughput, 78
Density Override LED, 33
density selection mode, 35
Determining Your SCSI Configuration, 14
diagnostic firmware, 4
diagnostic functions, 30
diagnostic results, 4
Diagnostics Menu, 23, 27, 29, 38, 41, 50
differential configurations, 44
Differential SCSI, 4
Digital Linear Tape, 2
Display Sensors function, 23, 29, 50, 58
DLT drives, 3, 4, 74
DOWN key, 21, 24, 25, 26, 27, 28, 29, 51, 52, 53, 54, 55, 56, 57
Downloadable Firmware, 3
Drive Operating Conditions, 34
drive operating status, 4
Drive POST, 32, 33, 34, 35
Drive SCSI ID Switches, 22
Drive Status, 32
Drive Type, 78

E
EMI/RFI Compliance, *iv*
EMI/RFI limit specifications, *iv*
Enable Mailbox parameter, 23, 24, 28
ENTER key, 20, 25, 26, 27, 28, 29, 45, 51, 52, 53, 54, 55, 56, 57, 58, 59
Environmental Considerations, 45
ESC key, 20, 25, 52, 53, 59
Event Counters function, 23, 29, 50, 57
Exabyte Emulation, 3

F

failure analysis, 4
Firmware Revision function, 23, 29, 50, 51, 52, 53
formatted capacity, 2
Front Panel Switches and Indicators, 20

H

Hierarchical Storage Management, 2, 74
host adapter, 57
host adapter card, 12
Host Bus Adapter interface card, 6
host computer, 3, 6, 12, 14, 17, 18, 22, 74
HSM, 2, 74

I

I/O connector, 12, 44
Init Mapping parameter, 23, 24, 26
Init Scan Barcodes parameter, 23, 24, 27
Install Cleaning Cartridge, 11
installation, 6
installation of firmware updates, 3
Installation Problems, 44
Installing SCSI Cables, Jumpers and Terminators, 14
Installing the Backup Software, 18
Installing the Cable Channel, 71
Installing the Scalar 218M into the Rack, 71
interchange compatibility, 4
interface cable, 14, 22

J

jackscrews, 17, 44
jumpers, 14, 15

L

LCD, 21, 74
LEFT key, 21, 24, 51, 53, 54, 55, 56, 57
Library and Drive Operational Problems, 45
Library Cartridge Change Time, 78
library cartridge inventory, 3
Library Error Messages, 45
Library Indicators/Controls, 78
Library Interface, 78
Library media type, 78
Loading a Cartridge into Drive, 40

M

Maintainability, 3
Manual Cartridge Use, 3
Manual Head Cleaning Procedure, 41
Manually Loading/Unloading a Cartridge to/from the Storage Shelves, 39
Map Slots & Drives function, 23, 27, 29, 50, 53
media cartridge handling mechanism, 3
media durability, 2
Media Picker, 3, 8, 54, 55, 56, 57, 74, 75
MENU key, 20, 24, 41
Moving a Cartridge to a Drive or Storage Slot, 38
Moving a Cartridge to the Mailbox Slot, 38
Multi-function Operator Panel, 3

N

near-line data storage, 2
necessary tools, 6
Normal Maintenance, 39
Normal Operations, 32

O

off-line data storage, 2
Off-Line Mode, 26, 38, 41
Off-Line Mode menu, 23, 24
Off-Line Time parameter, 23, 24, 26
On/Off Switch, 20
On-Line Mode, 24, 26, 32, 41, 45
Open Drive Door function, 23, 29, 41, 50, 51
Operate Handle LED, 32, 33, 41
operating environment, 7
operating parameters, 24
Operation Log function, 23, 29, 50, 57
Options, 4

P

packing foam, 8
packing materials, 6
Pick From Drive function, 23, 29, 50, 56
Pick From Mailbox function, 23, 29, 38, 50, 55
Pick from Slot function, 23, 29, 50, 55
Place in Drive function, 23, 29, 50, 57
Place in Mailbox function, 23, 29, 38, 50, 56
Place In Slot function, 23, 29, 50, 56
Pos Picker at Drv function, 23, 29, 50, 54
Pos Picker at Mbox function, 23, 29, 50, 54
Pos Picker at Slot function, 23, 29, 50, 54

POST, 74
Power Up Checks, 32
Powering on the System, 17
Power-on Self-Test, 32, 74
Precautions, *x*
Prepare and Install the Data Cartridges, 9
Preparing the Library for Installation, 7
Preparing the Rack, 66
Product Sign-On parameter, 23, 24, 25

R

Rear Panel Switches and Connectors, 22
Removing the Shipping Bracket, 8
Requirements, 6
restore operations, 32
Return Merchandise Authorization, 74
RIGHT key, 21, 24, 25, 51, 53, 54, 55, 56, 57
RMA number, 74
Run Demo function, 23, 29, 50, 59

S

Safety Warnings, *ix*
Scan Barcodes sub-function, 27
SCSI adapter, 44
SCSI adapter card, 44
SCSI Adapter Card Installation, 44
SCSI bus, 11, 14, 22, 30, 32, 75
SCSI bus configuration, 44
SCSI cables, 14, 15, 17, 44
SCSI Cabling, 44
SCSI chain, 12
SCSI channel, 22, 28, 75
SCSI configuration, 14, 15
SCSI connector, 14, 17, 22
SCSI device, 2, 11, 14, 28, 44
SCSI host adapter, 57
SCSI ID, 22, 25, 57, 74
SCSI IDs, 44
SCSI II bus, 44
SCSI interface cables, 17
SCSI interface card, 12, 17

SCSI jumpers, 22
SCSI terminator, 22, 75
Serial Dnld Flash Mode, 23, 30
Set SCSI ID parameter, 11, 23, 24, 25
Setting the SCSI IDs, 11
shielded data cables, *iv*
shipping bracket, 8
single-ended configurations, 44
slide rails, 6
streaming tape cartridge, 2
surrounding environment, 7
sustained data transfer rate, 2
System Integrity, 3

T

tape density, 4
Tape in Use, 32, 33
Term Power LED, 32
Termination, 44
terminator, 14, 15, 17, 32

U

UNLOAD button, 33, 41
Unpacking and Inspecting, 6
UP key, 21, 24, 25, 26, 27, 28, 29, 51, 53, 54, 55, 56, 57
Use Cleaning Tape LED, 32, 39, 40, 78
Using the Mailbox, 38, 40

V

valid cartridge locations, 3
Verify SCSI Bus parameter, 23, 24, 28

W

warranty, *ii, iii, 6, 74*
Write Flash Memory mode, 30
Write Flash Memory Mode, 23, 30
write-protect switch, 9, 10, 36, 45
Write-Protected LED, 32